

# Unit 1

## Skills Workbook

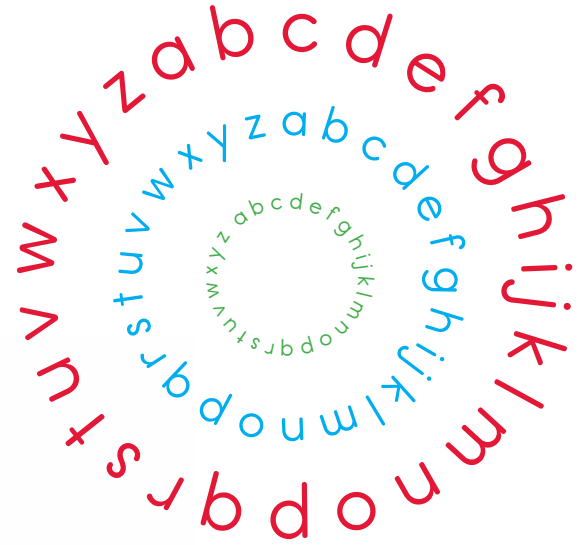

Core Knowledge Language Arts® • New York Edition • Skills Strand



Core Knowledge®

KINDERGARTEN



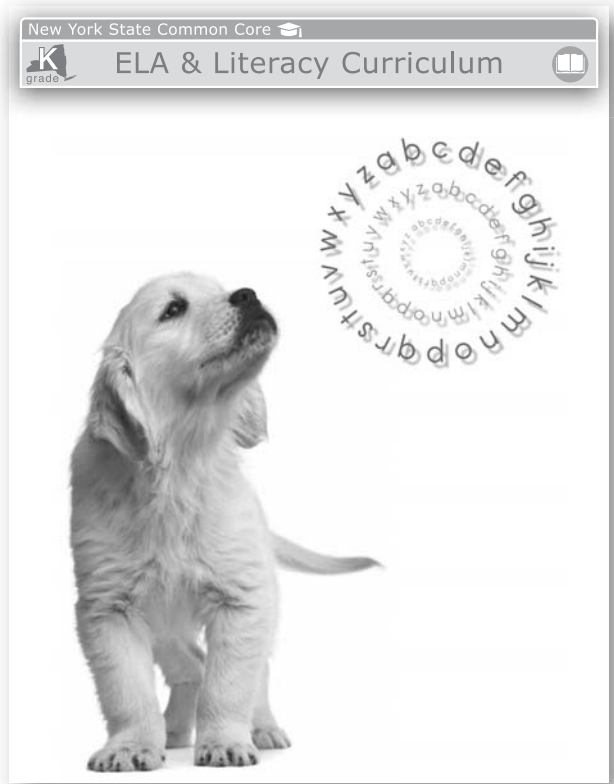

# Unit 1

## Workbook

Skills Strand  
KINDERGARTEN

Core Knowledge Language Arts®  
New York Edition



## Creative Commons Licensing

This work is licensed under a Creative Commons Attribution-NonCommercial-ShareAlike 3.0 Unported License.



### You are free:

- to Share** — to copy, distribute and transmit the work
- to Remix** — to adapt the work

### Under the following conditions:

**Attribution** — You must attribute the work in the following manner:

*This work is based on an original work of the Core Knowledge® Foundation made available through licensing under a Creative Commons Attribution-NonCommercial-ShareAlike 3.0 Unported License. This does not in any way imply that the Core Knowledge Foundation endorses this work.*

**Noncommercial** — You may not use this work for commercial purposes.

**Share Alike** — If you alter, transform, or build upon this work, you may distribute the resulting work only under the same or similar license to this one.

### With the understanding that:

For any reuse or distribution, you must make clear to others the license terms of this work. The best way to do this is with a link to this web page:

<http://creativecommons.org/licenses/by-nc-sa/3.0/>

Copyright © 2013 Core Knowledge Foundation  
[www.coreknowledge.org](http://www.coreknowledge.org)

All Rights Reserved.

Core Knowledge Language Arts, Listening & Learning, and Tell It Again! are trademarks of the Core Knowledge Foundation.

Trademarks and trade names are shown in this book strictly for illustrative and educational purposes and are the property of their respective owners. References herein should not be regarded as affecting the validity of said trademarks and trade names.

# Unit 1

## Workbook

This workbook contains worksheets which accompany many of the lessons from the *Teacher Guide* for Unit 1. Each worksheet is identified by the lesson number in which it is used. The worksheets in this book do not include written instructions for students because the instructions would have words that are not decodable. Teachers will explain these worksheets to the students orally, using the instructions in the teacher guides. The workbook is a student component, which means each student should have a workbook.



**Dear Family Member,**

This year we will be using the Core Knowledge Language Arts program with our Kindergarten students.

The program consists of two “strands” of instruction. The first strand, the Skills Strand, strives to teach students the mechanics of reading and writing using a phonics approach. As part of this strand, students will learn how to hear sounds in words and write “pictures of sounds,” also known as letters.



For the first few weeks students will be learning to make simple writing strokes—lines, circles, humps, cups, etc.—while also learning to hear words in sentences. Next, students will learn to hear sounds in words. When that skill is in place, they will begin to learn the letters we use to represent sounds. From time to time we will send you a worksheet like this one to explain what is being taught in the program. It will inform you of activities you can do at home to supplement and solidify the learning your child is doing at school.

The second strand, Listening & Learning, strives to build students’ vocabulary and background knowledge through oral language experiences. As part of this strand, students will listen to stories and nonfiction selections read aloud, participate in discussions, and complete vocabulary work.





**Dear Family Member,**

In class, we have been practicing vertical lines. Knowing how to draw a vertical line is important because vertical lines are found in a number of letters (e.g., 't', 'd', 'h', etc.). Please have your child trace the dotted vertical lines on the front and back of this worksheet, starting at the stars and moving down.

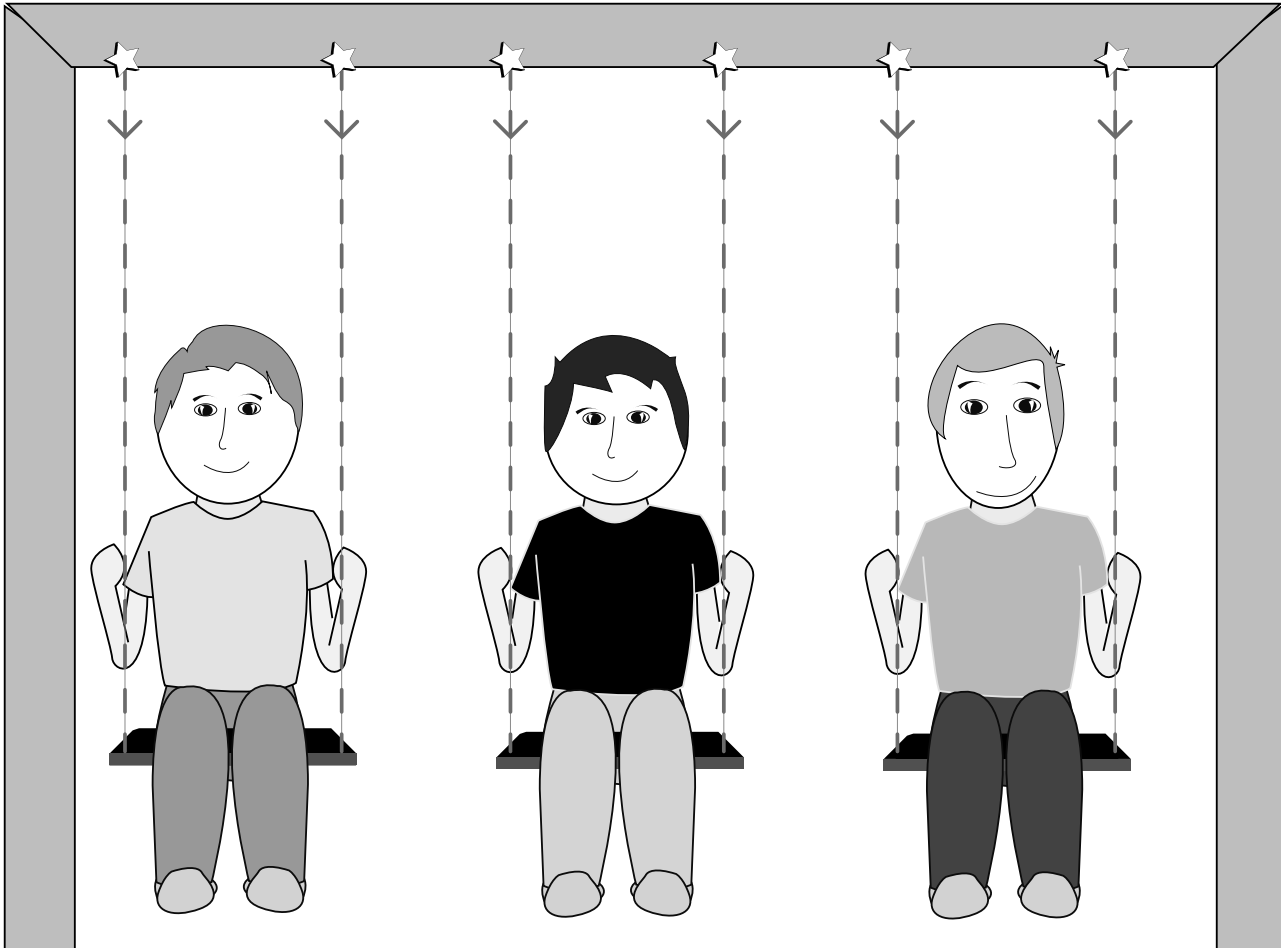

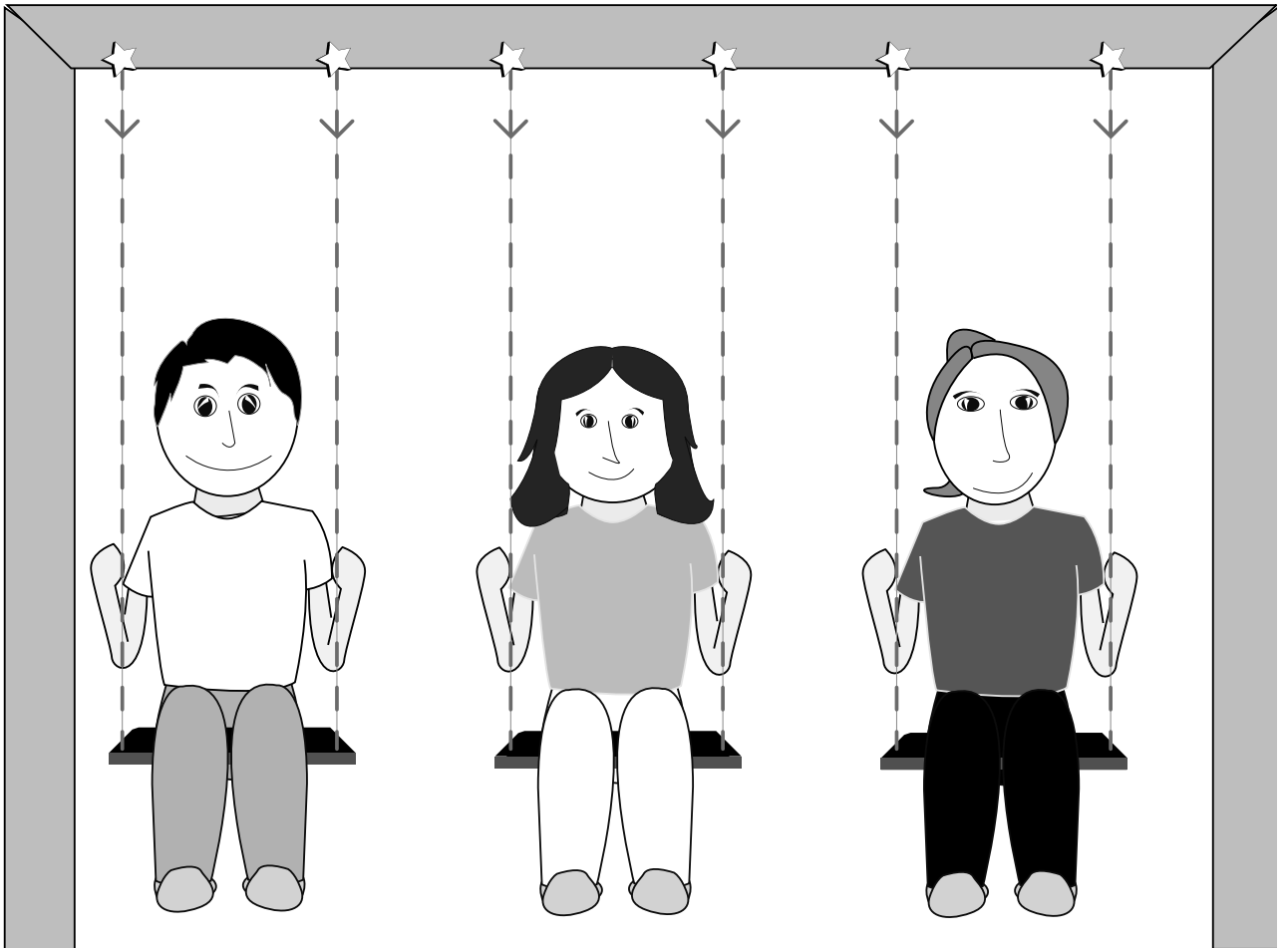

*Directions: Have students trace the dotted vertical lines, starting at the stars and moving down. (There are more on the back.)  
Students may color the picture (optional).*

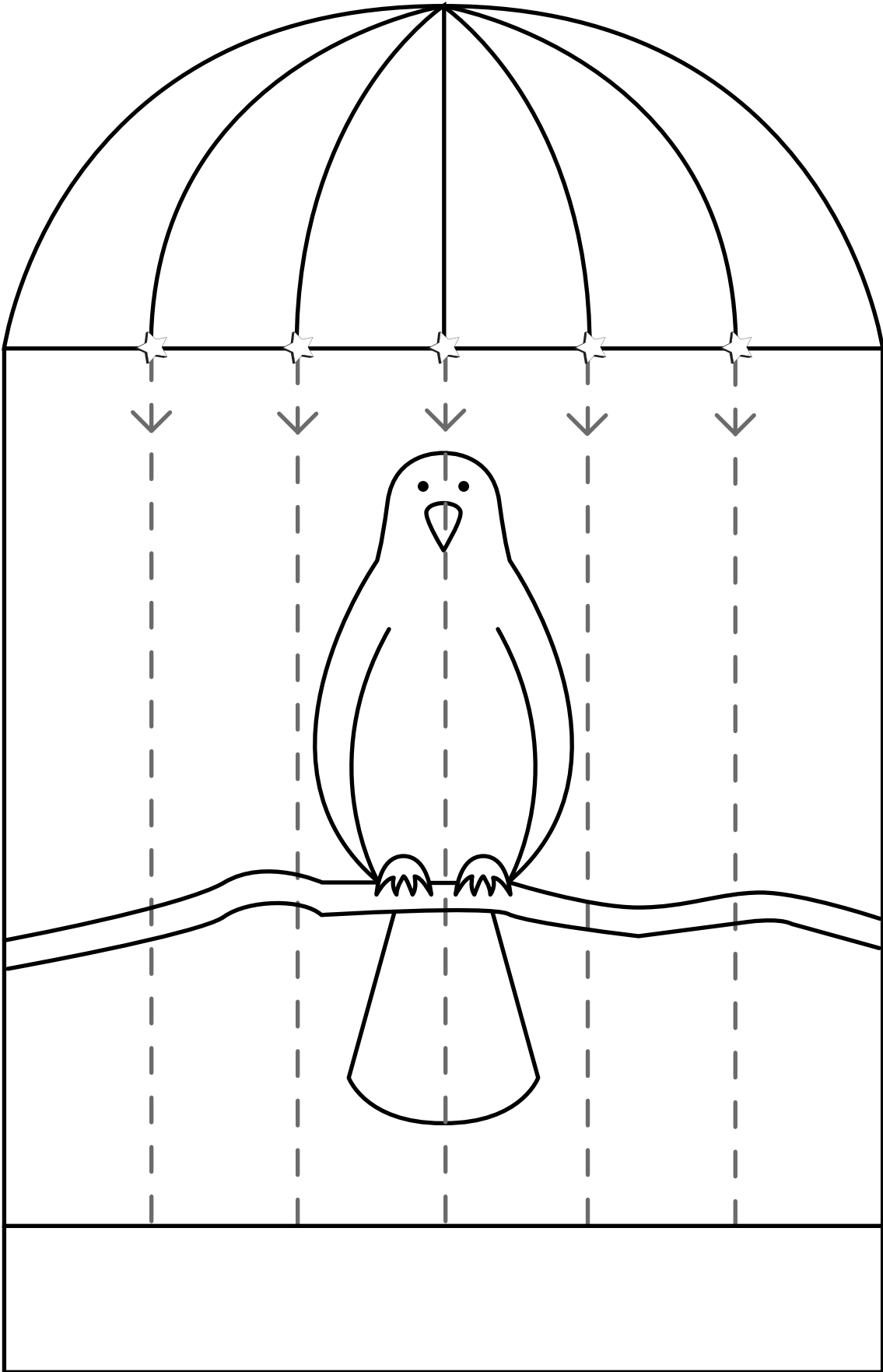

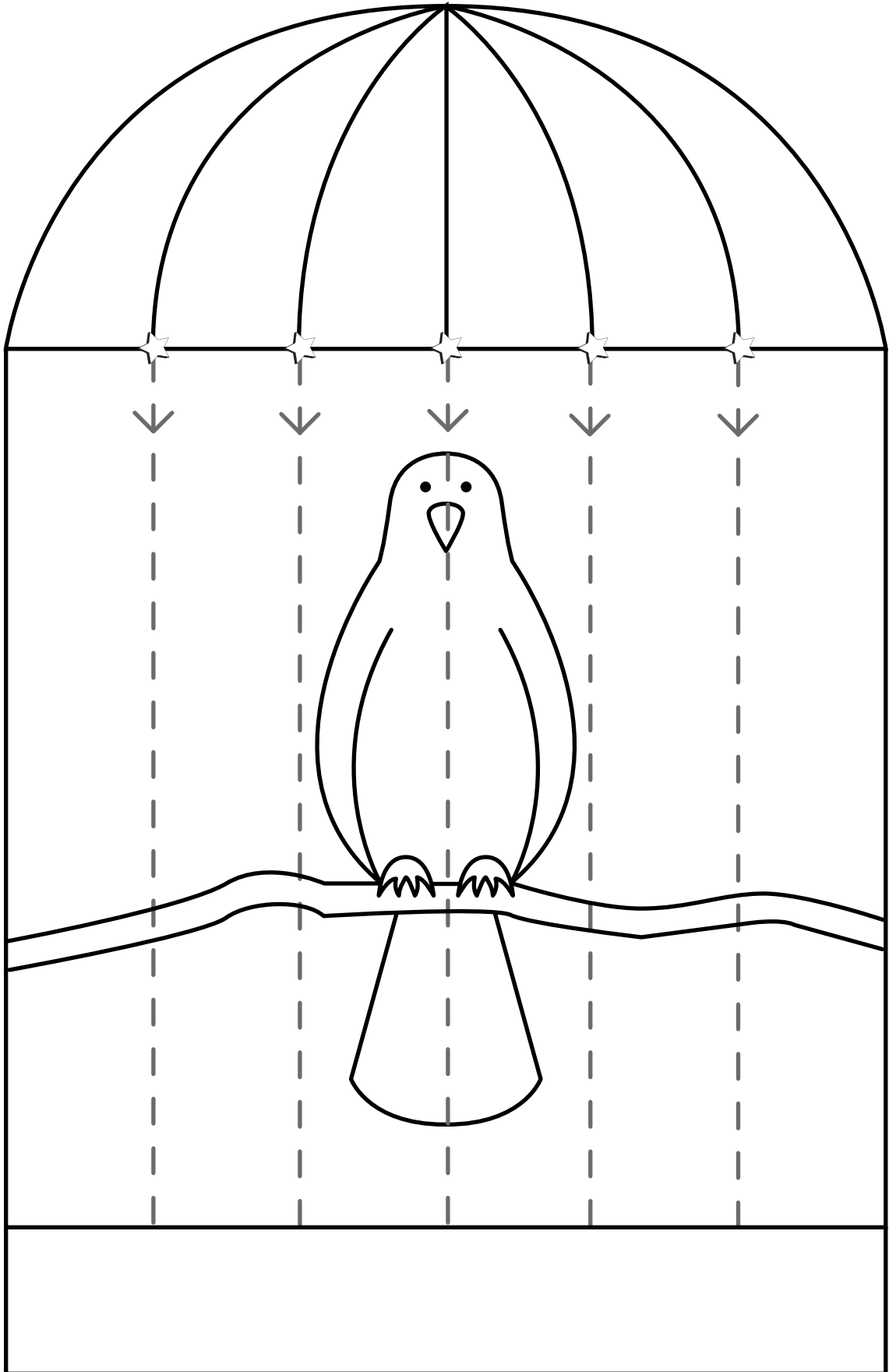

**Dear Family Member,**

In our class, we have been working on prewriting skills. Your child has not yet been taught to write letters but has been developing his or her fine motor skills. Below are some suggestions for activities you can do at home that will allow your child to practice and develop his or her hand and arm muscles and hand-eye coordination. Both are very important when learning how to use a writing utensil.



Have your child:

- build with blocks
- transfer water from one container to another with an eyedropper or spoon
- pick up small objects like beads with their eyes closed
- use tweezers to pick up crumpled bits of paper
- cut up junk mail with child-friendly scissors
- string beads onto yarn or string
- scrunch up a sheet of paper in one hand
- mold and roll playdough into shapes
- draw and color pictures

We recommend that your child draw and color with small pieces of crayon. Drawing with crayons provides greater sensory input than drawing with pencils or markers. This is because the wax has greater resistance to the paper than graphite or ink; the push-and-pull motion strengthens finger and hand muscles. The small size of the crayon discourages creative grips and encourages the tripod grip (shown above). Using the tripod grip will give your child better control of the shapes they draw and increase the length of time your child can write.

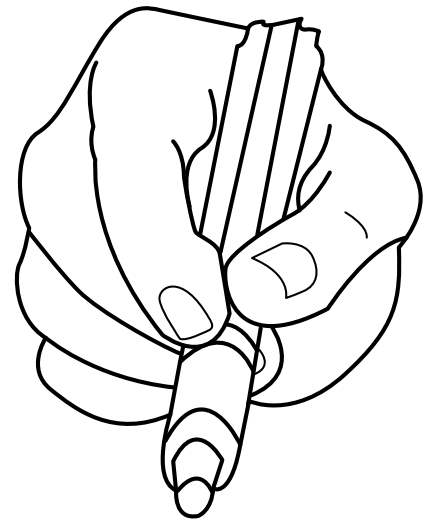



Name \_\_\_\_\_

Date \_\_\_\_\_

## Blending Pretest

### Scoring Sheet

Examples: /m/ ... /e/ – me      /s/ ... /a/ ... /d/ – sad

1. /s/ ... /ae/ (say) \_\_\_\_\_
2. /n/ ... /oe/ (no) \_\_\_\_\_
3. /f/ ... /i/ ... /sh/ (fish) \_\_\_\_\_
4. /s/ ... /u/ ... /n/ (sun) \_\_\_\_\_
5. /s/ ... /i/ ... /t/ (sit) \_\_\_\_\_
6. /m/ ... /a/ ... /t/ (mat) \_\_\_\_\_
7. /t/ ... /e/ ... /n/ (ten) \_\_\_\_\_
8. /b/ ... /a/ ... /d/ (bad) \_\_\_\_\_
9. /f/ ... /l/ ... /i/ ... /p/ (flip) \_\_\_\_\_
10. /sh/ ... /i/ ... /p/ (ship) \_\_\_\_\_

### Notes:

### Interpretation:

8 or more correct: **Strong**

5–7 correct: **Fair to Good**

4 or fewer: **Weak**

Total Correct: \_\_\_\_\_





*Directions: Have students trace the dotted horizontal lines, starting at the stars and moving to the right. (There are more on the back.) Students may color the pictures (optional).*

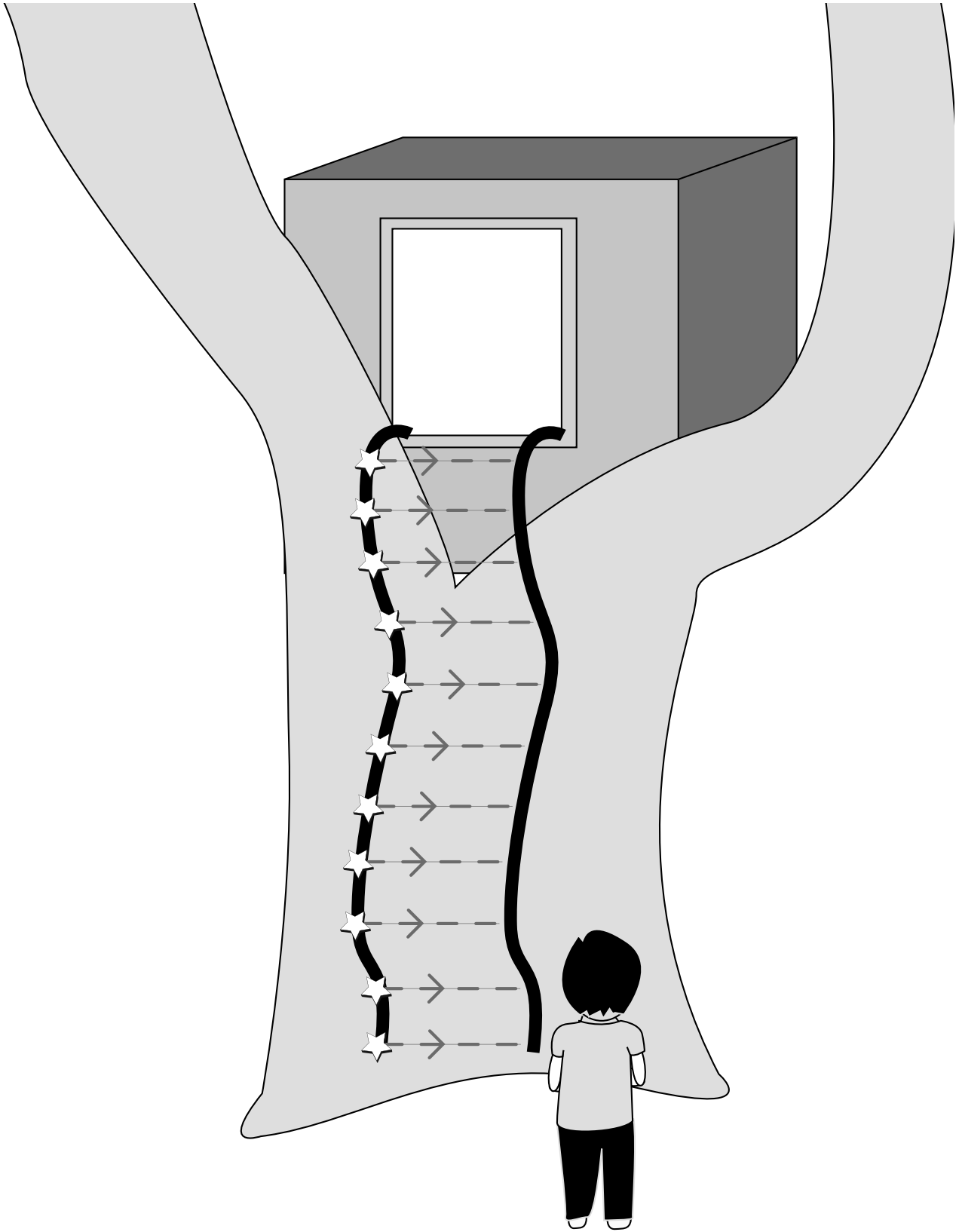

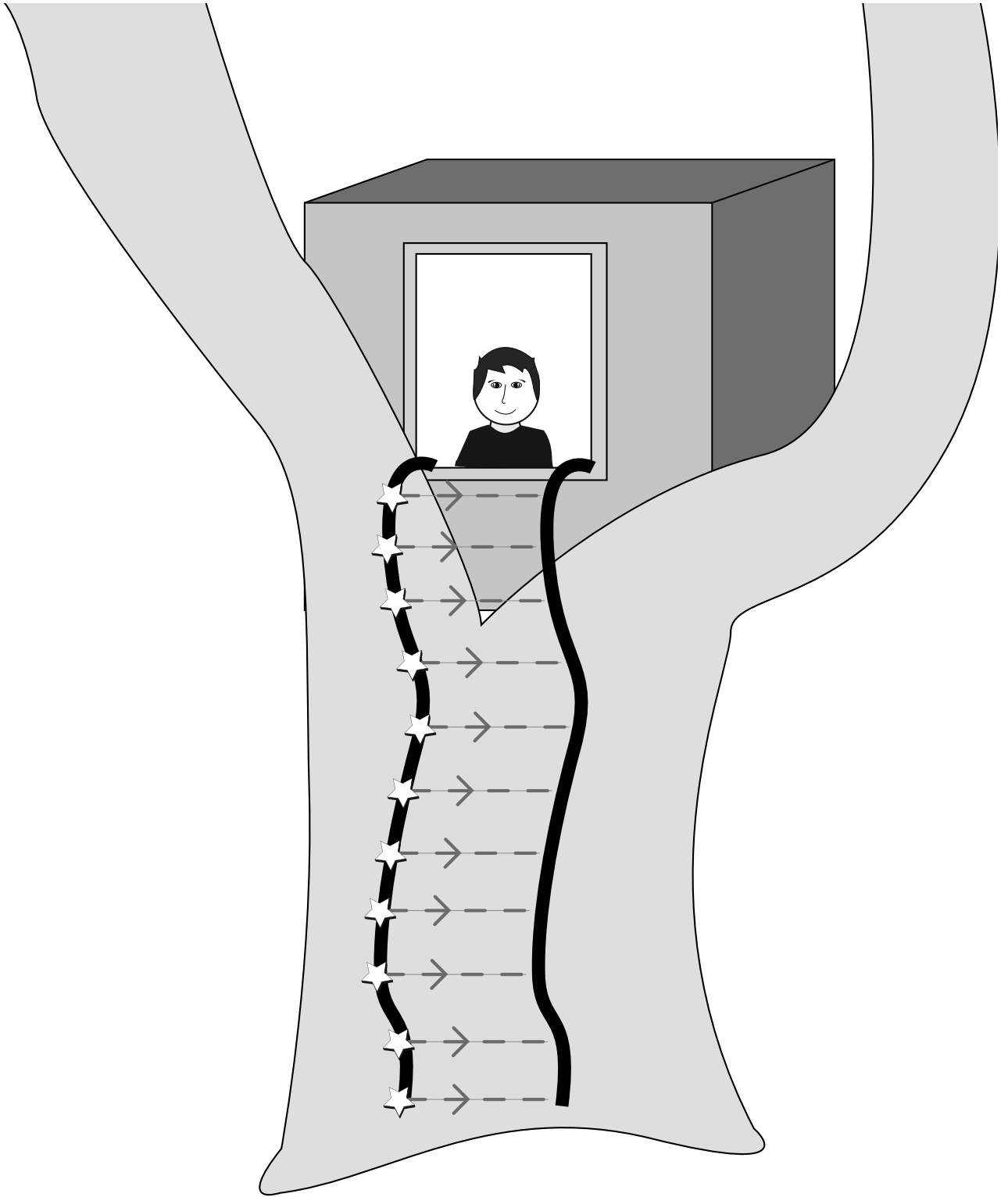

**Dear Family Member,**

In class, we have been practicing horizontal lines. Knowing how to draw a horizontal line is important because horizontal lines are found in a number of letters (e.g., 't', 'f', 'z', etc.). Please have your child trace the dotted horizontal lines on the front and back of this worksheet, starting at the stars and moving to the right.

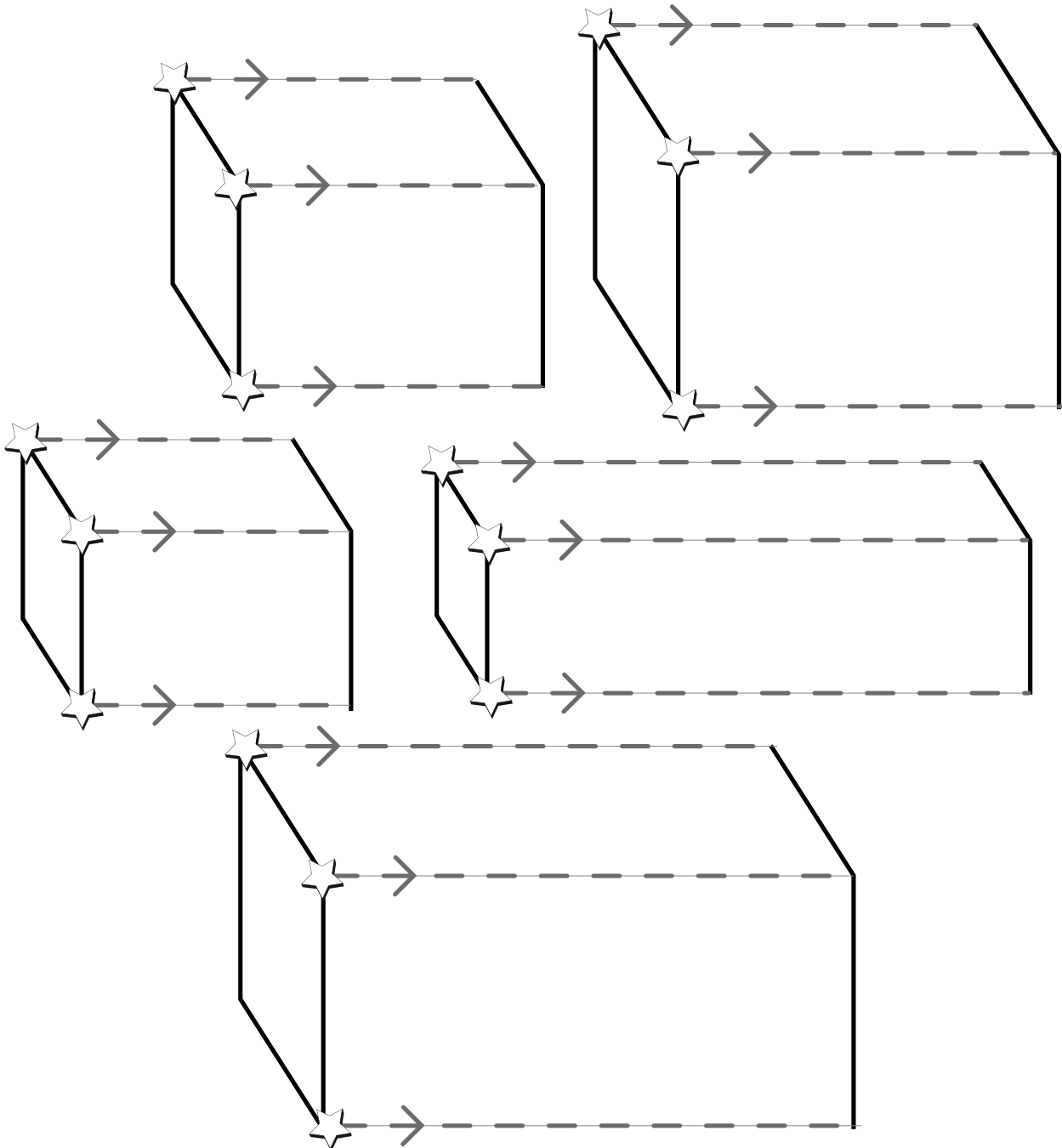

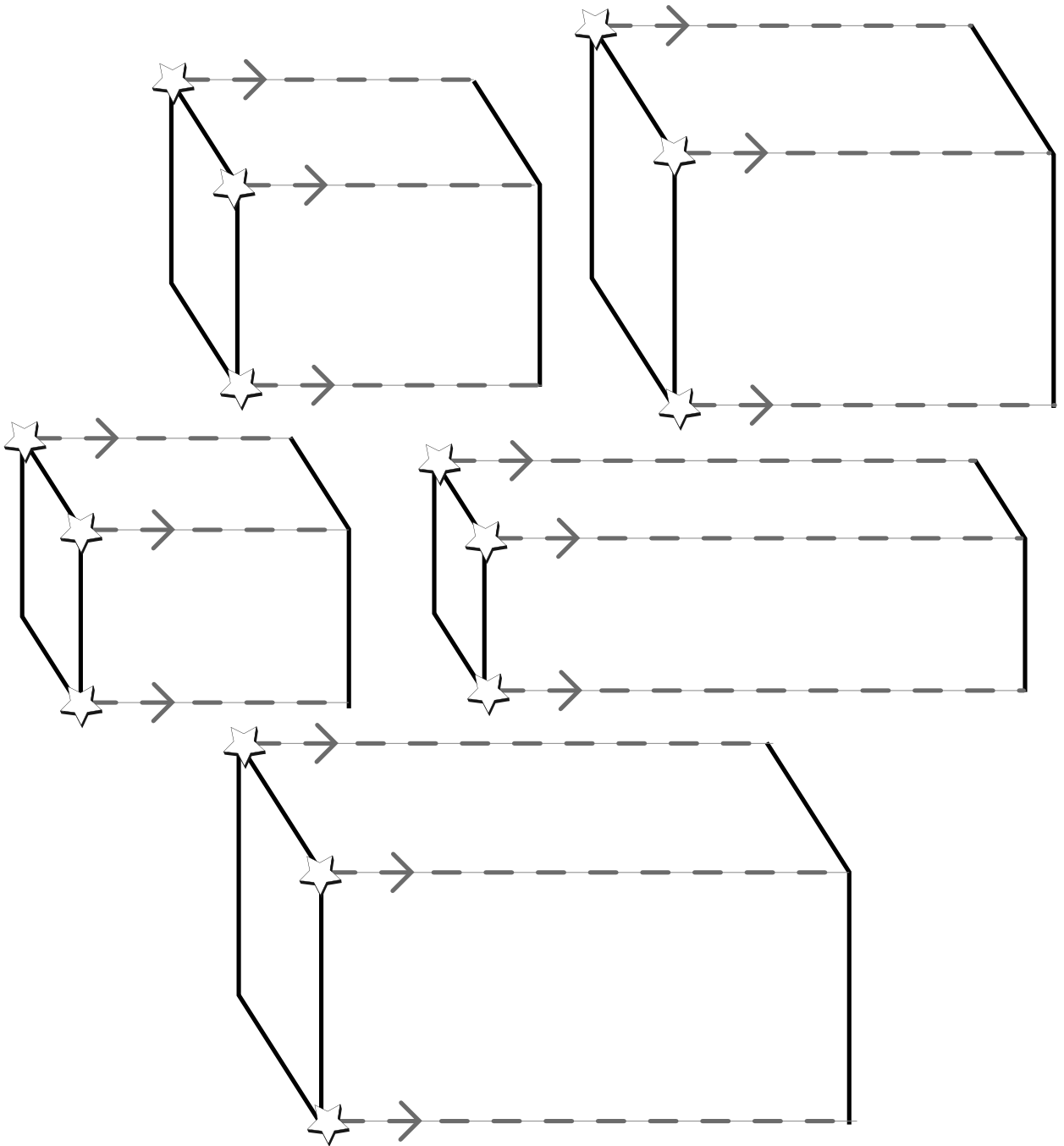

*Directions: Have students simultaneously name and point to the pictures in each row from left to right. Students should identify the pictures in the top row, then the second row, then the third row, and then the bottom row.*

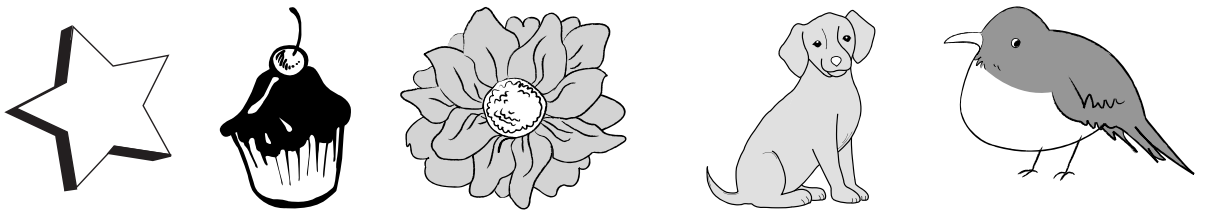
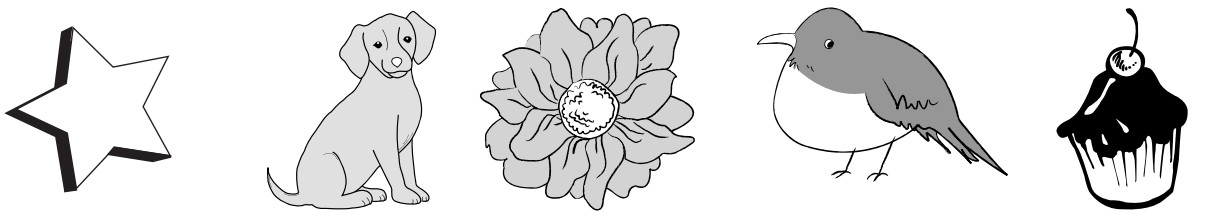
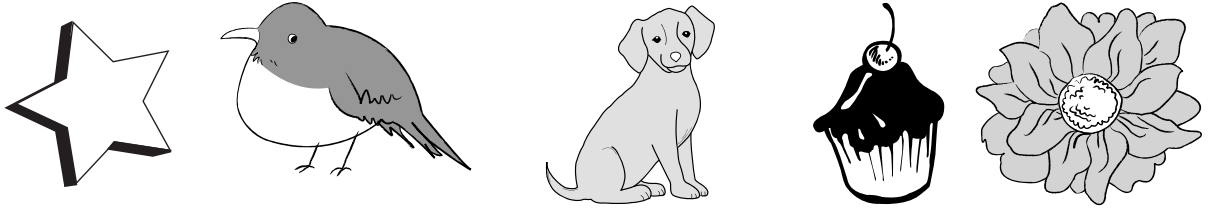

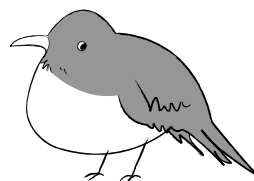
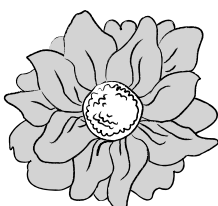
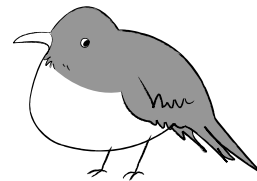
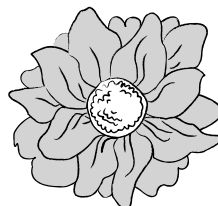
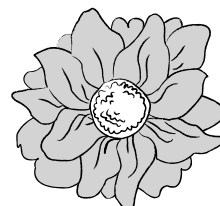
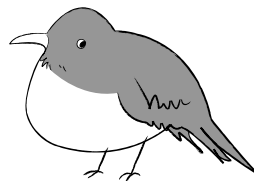
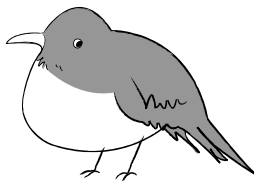
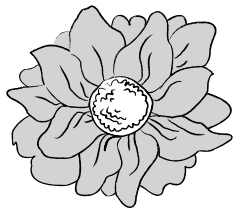

**Dear Family Member,**

In class, we have been practicing circles. Knowing how to draw a circle is important because circles are found in a number of letters (e.g., 'b', 'd', 'o', etc.). Please have your child trace the dotted circles on the front and back of this worksheet, starting at the stars and moving to the left.

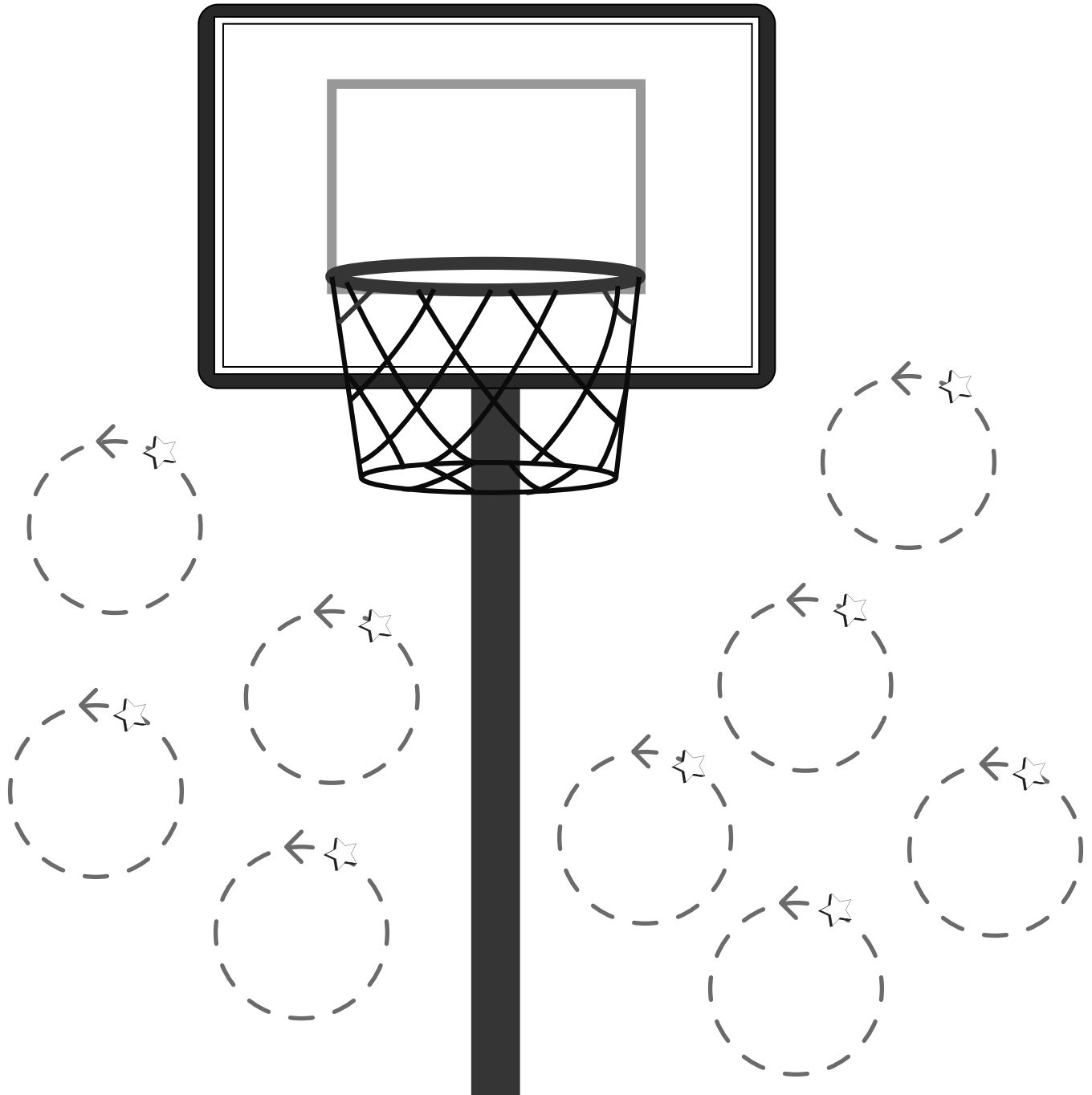

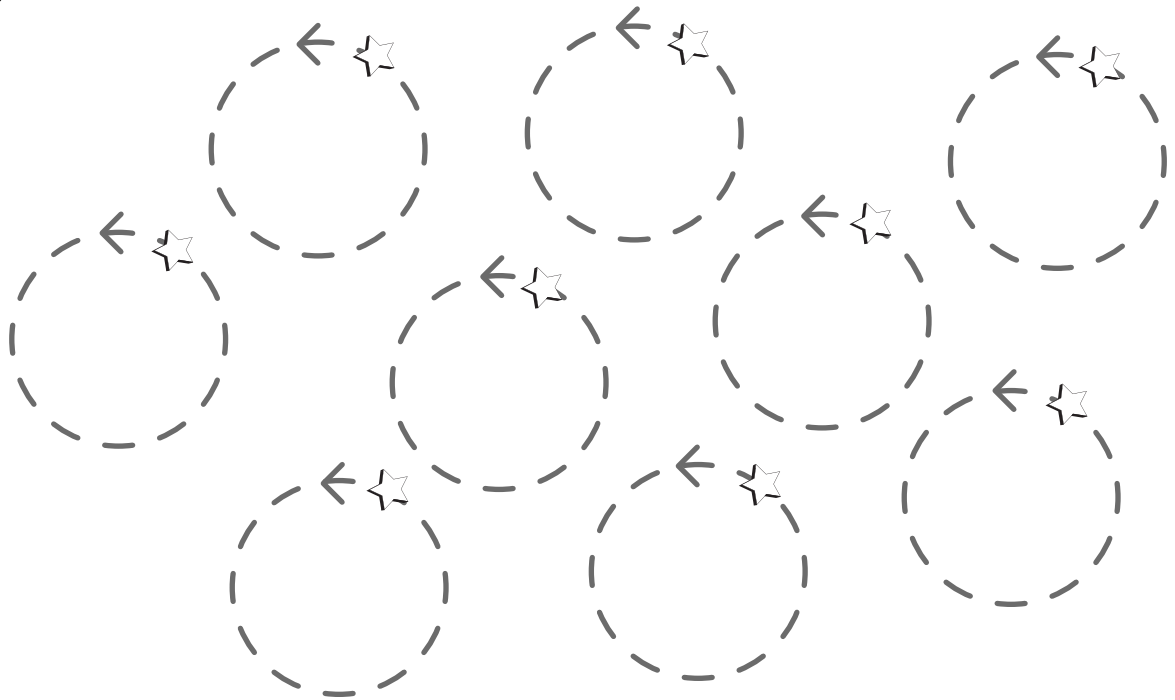
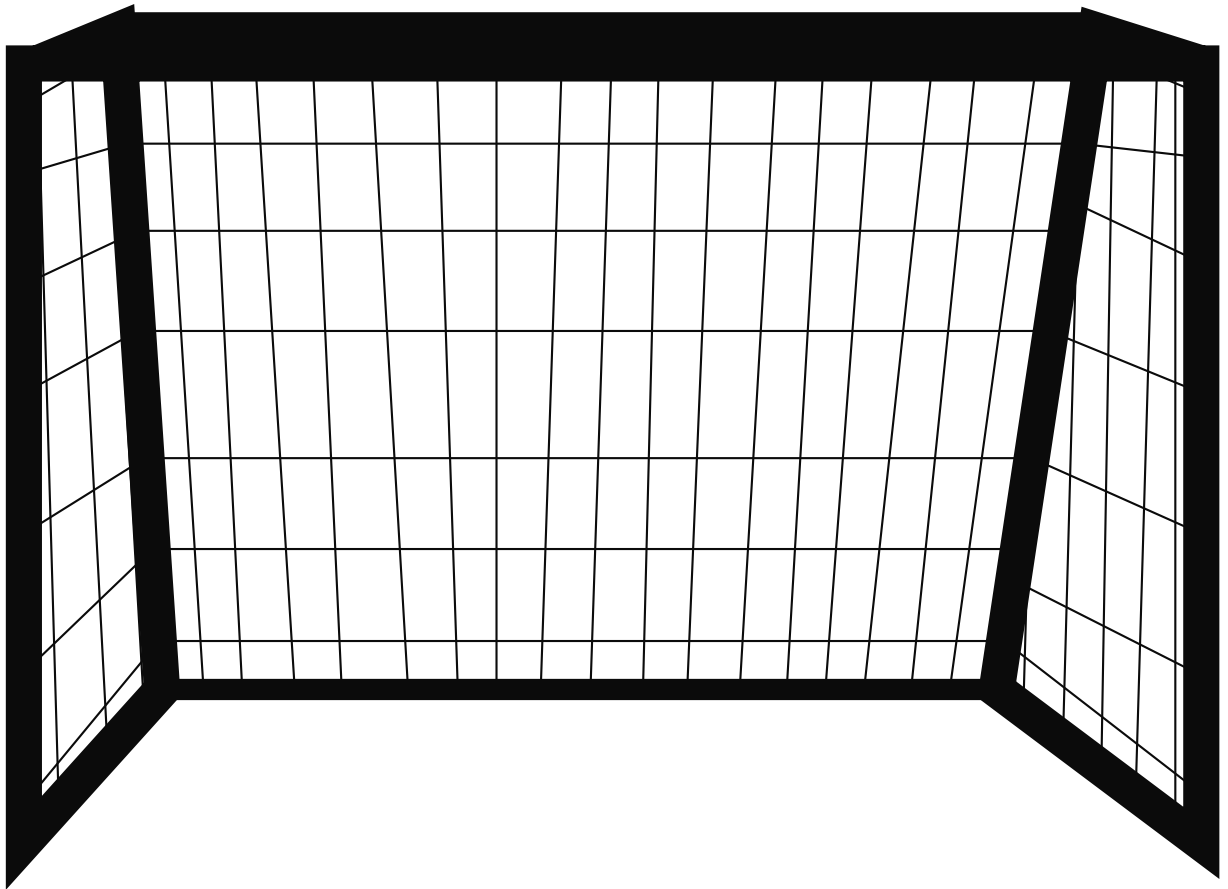





Name \_\_\_\_\_

Date \_\_\_\_\_

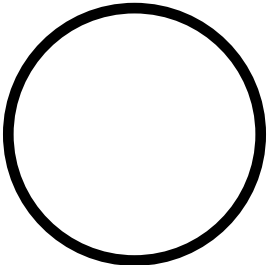

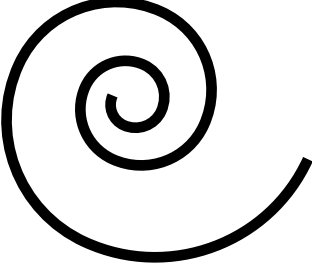
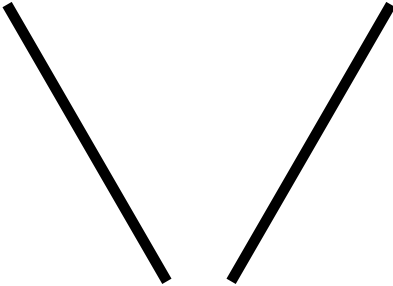
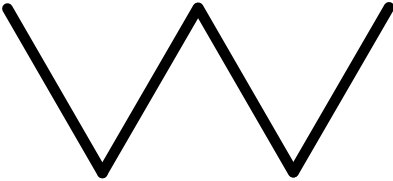
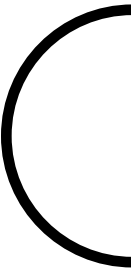

*Directions: Ask students to copy each item.*

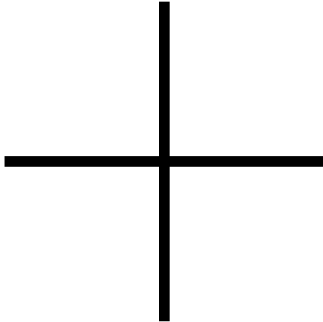

Name \_\_\_\_\_

Date \_\_\_\_\_

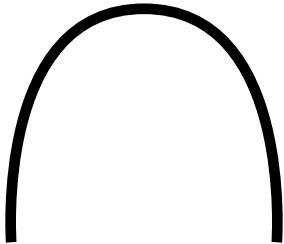

*Directions: Ask students to copy each item.*

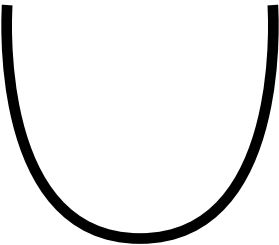
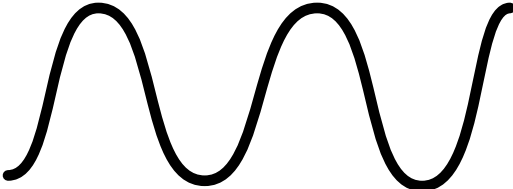
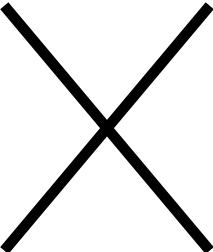
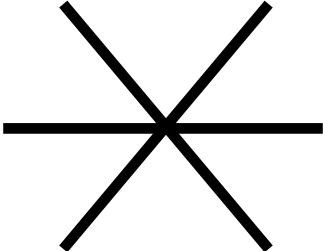
**Total Points:** \_\_\_\_\_

Directions: Ask students to trace the dotted circles, starting at the stars and moving to the left. Students may color the pictures (optional).



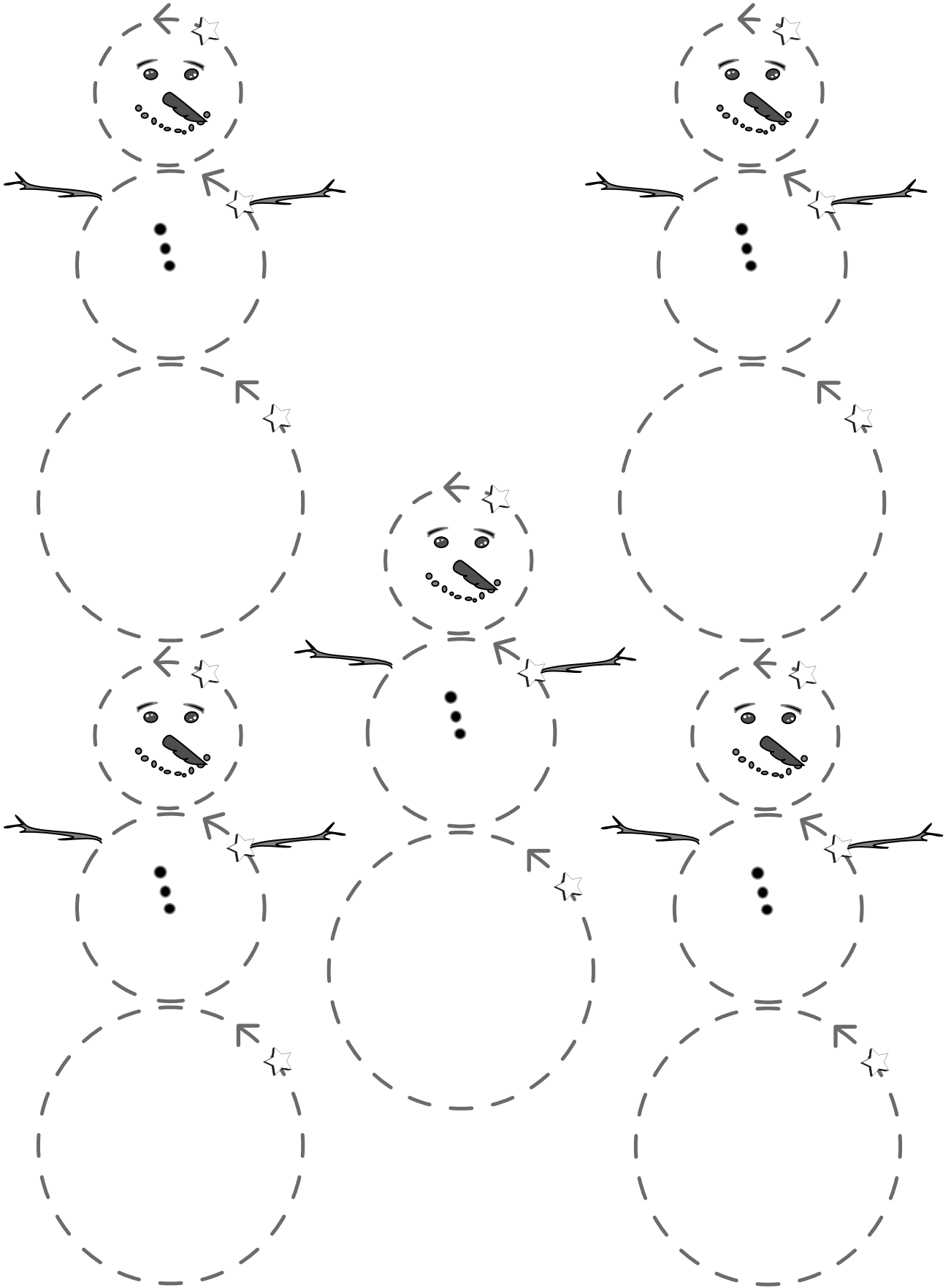

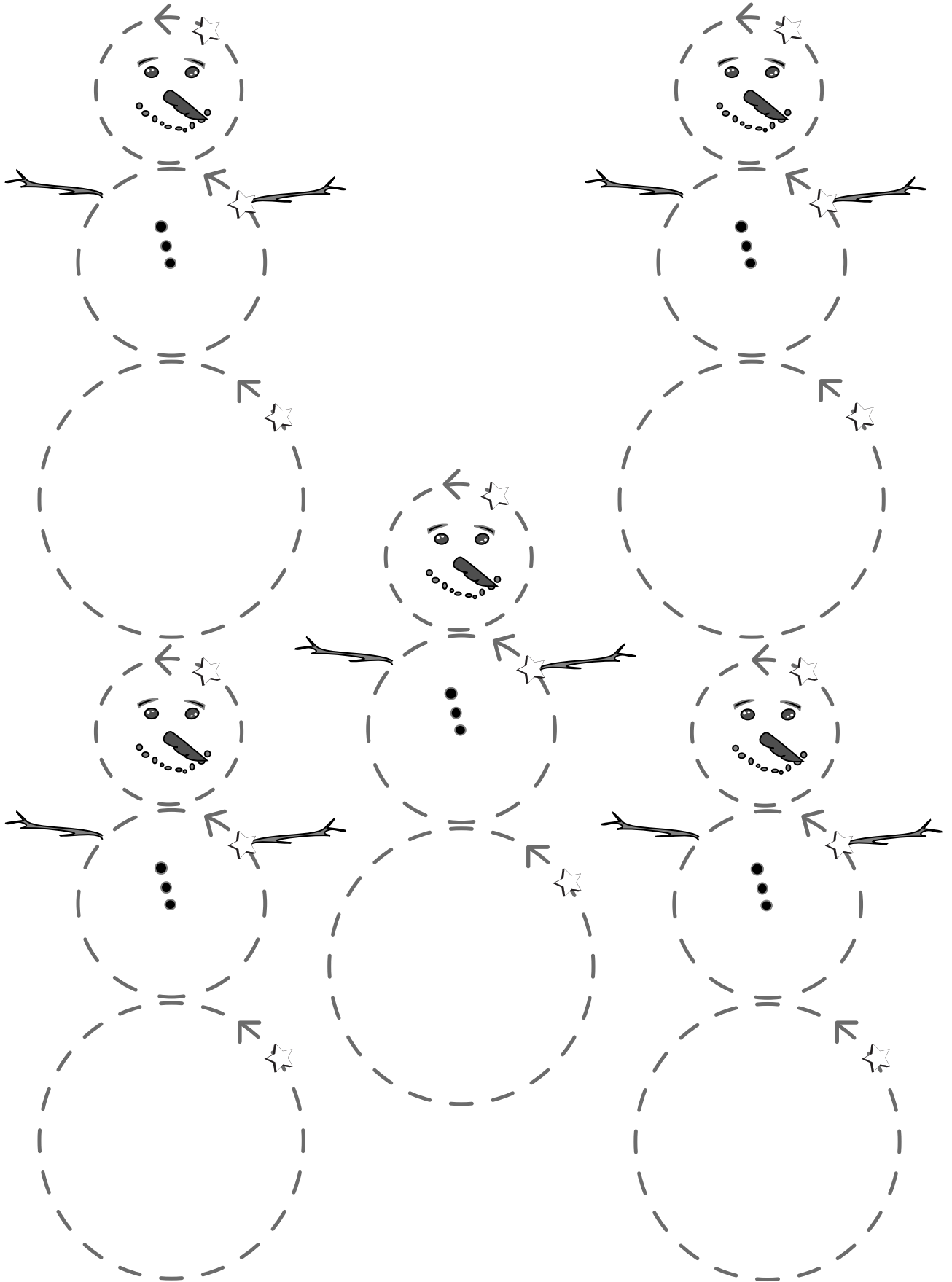
**Dear Family Member,**

Up to this point in language arts class, your child has been working on noise and word awareness. Your child has not yet been taught to identify the specific sounds of English or read and write letters, but we are building up to these skills. Below are some suggestions for activities you can do at home that will allow your child to practice listening to noises and words. In addition to doing these activities, it is important that you read to your child every day.

**1. Listening to Noises and Identifying Them**

Spoken language is made up of sounds, and the English writing system represents these sounds with letters. Listening carefully to sounds and noises is an important part of learning how to read. This activity teaches your child how to listen carefully and to think and speak about what they have heard. You can do this activity at home, when you are on a walk, when you are at the grocery store, etc.

- Find several household objects that make distinctive noises, e.g., keys, scissors, etc.
- Use one object to make a noise.
- Ask your child what noise he or she heard (e.g., jingling, slicing, etc.).
- Ask your child what made the noise (e.g., keys, scissors, etc.).
- Repeat multiple times, using various objects.
- Ask your child to compare and describe the noises. (Which one was the loudest? Which noise did he or she hear first or last?)

## 2. Recalling Noises

In language, sounds are combined to form words. The ability to hear these individual sounds and recall them is important for both reading and writing. Up to this point, your child has practiced listening to noises made by instruments and other objects. Recalling several noises and naming them in the order in which they occurred is very good preparation for recalling and naming the sounds in words.

- Make up to three noises in the kitchen, e.g., turn the water on, close a cabinet door, and tap a spoon on a plate.
- Ask your child what made the noises (e.g., water from faucet, cabinet door, spoon on plate).
- Repeat multiple times, using various objects.
- Ask your child to close his or her eyes.
- Make two or three of the familiar noises.
- Ask your child to name or recreate the noises in the order he or she heard them.

## 3. Counting Words

Words consist of strings of sounds; phrases and sentences consist of strings of words. Being aware of words and their order is important for learning to read. Counting words is quite difficult for young learners. Do not be surprised if your child cannot do this right away. Practice will help improve the skill.

- Read a story to your child.
- Pick one short sentence from the story with no more than five words. Say the sentence to your child. As you speak, lift one finger for each word in the sentence.
- Let your child try to lift his or her fingers for each word while saying the sentence.
- Note: If counting five words is too hard, choose a shorter sentence.
- Repeat multiple times.



*Directions: Ask students to trace the dotted lines, starting at the stars. Students may color the pictures (optional).*

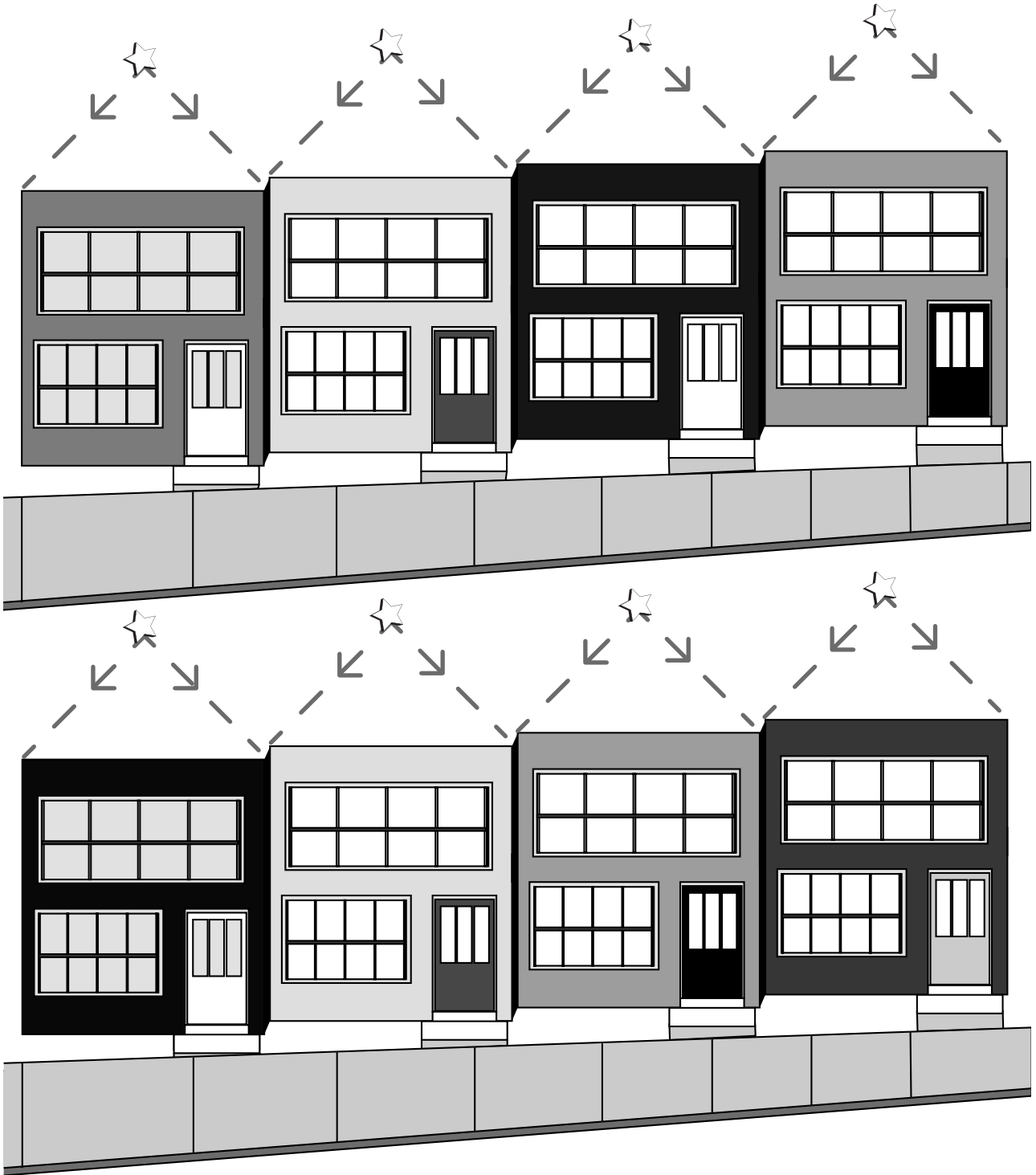

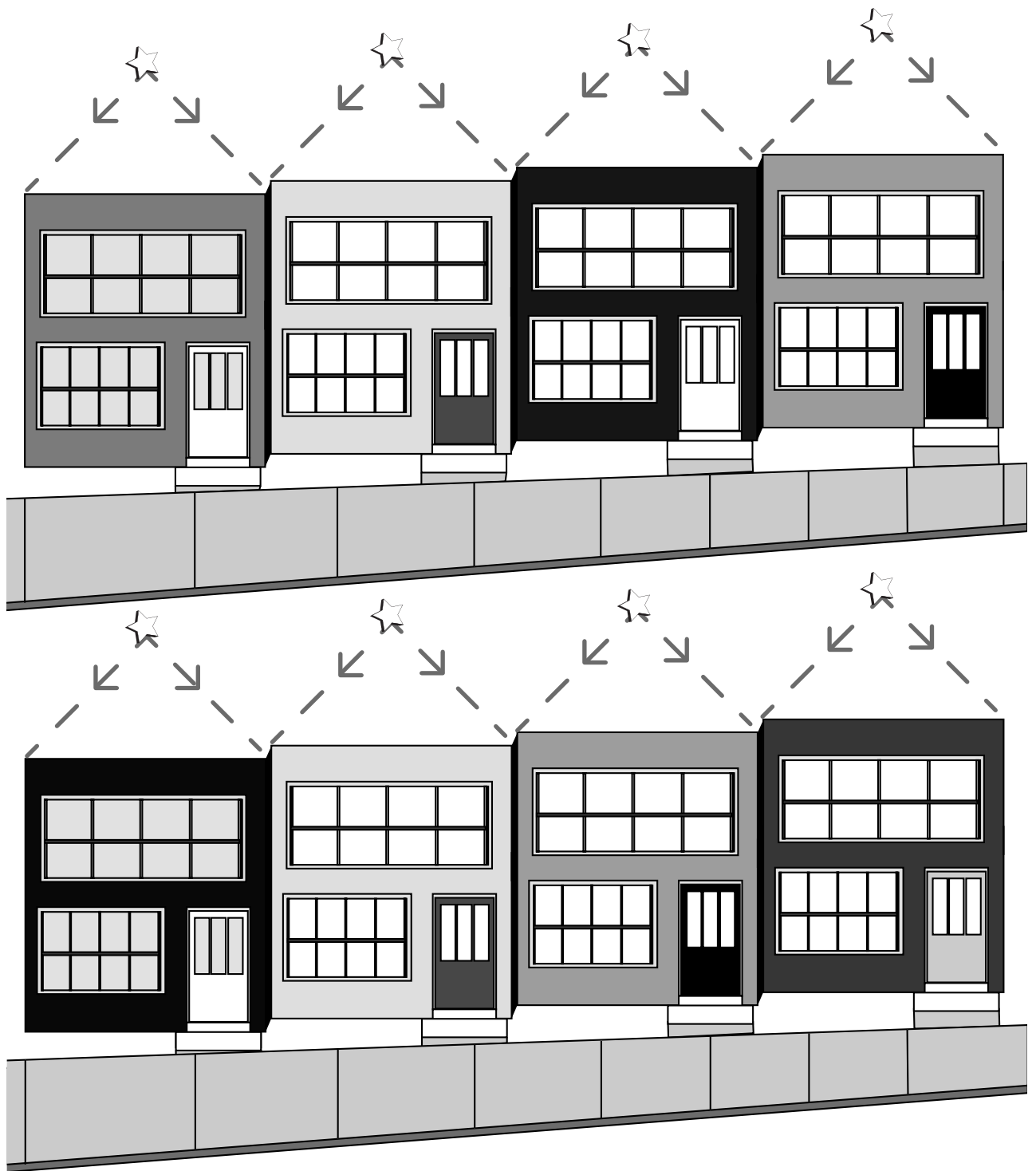

Directions: Ask students to simultaneously name and point to the pictures in each row from left to right. Students should identify the pictures in the top row, then the second row, then the third row, and then the bottom row.

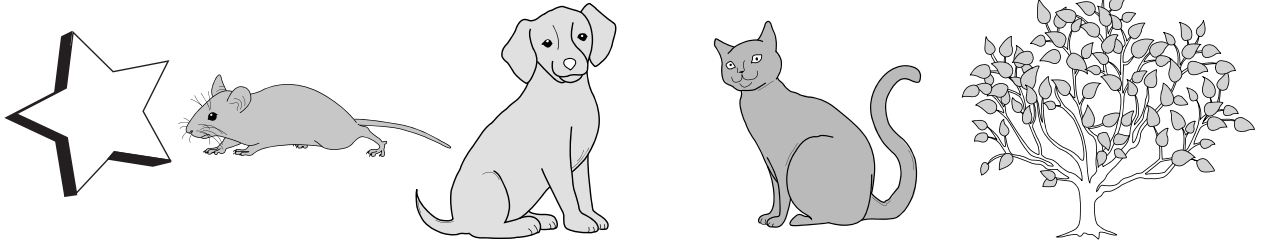

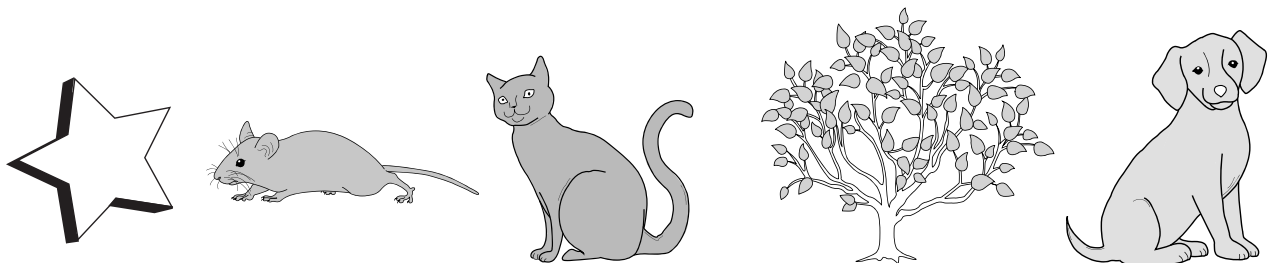
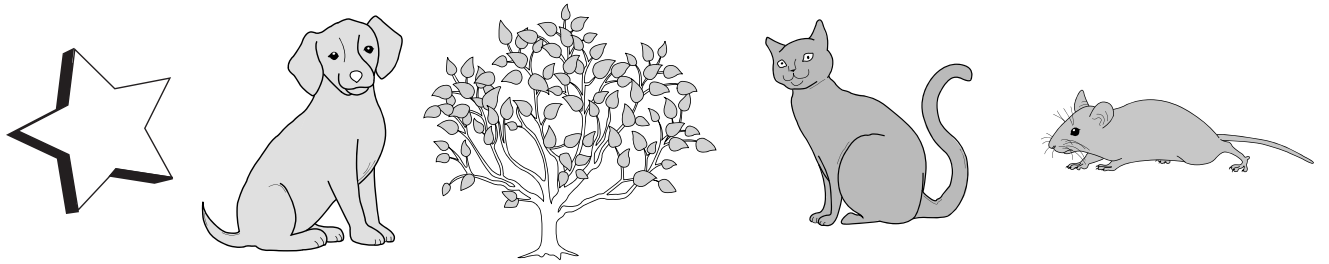
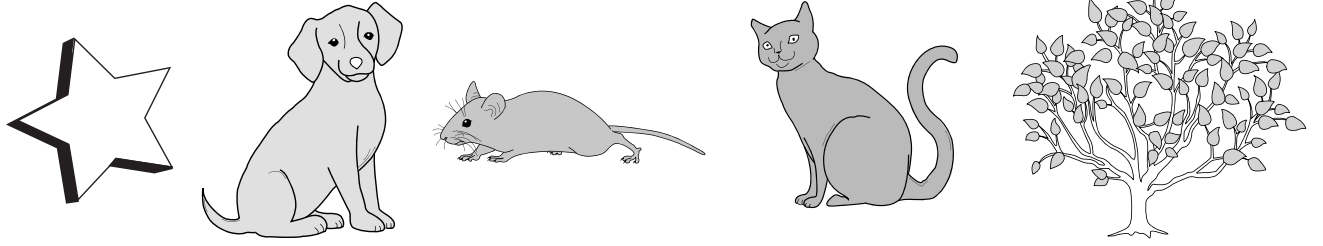

**Dear Family Member,**

In class, we have been practicing diagonal lines. Knowing how to draw a diagonal line is important because diagonal lines are found in a number of letters (e.g., 'k', 'v', 'x', etc.). Please have your child trace the dotted diagonal lines on the front and back of this worksheet, starting at the small stars on top of each larger star. Your child may color the page.

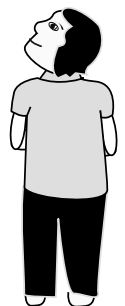
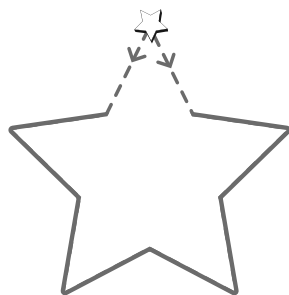
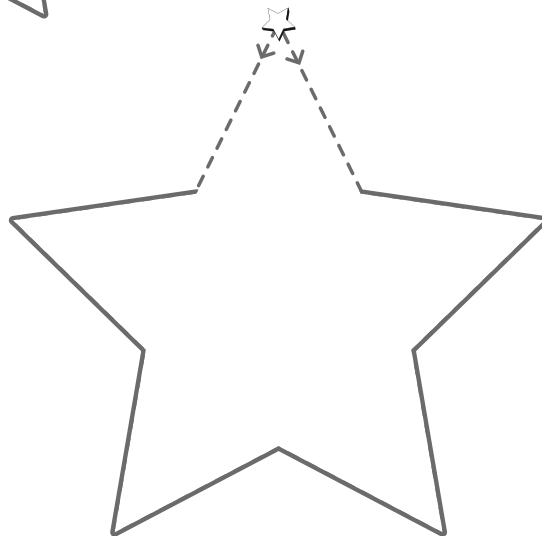
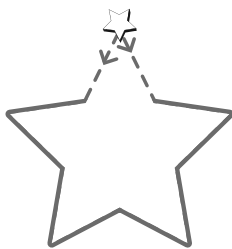
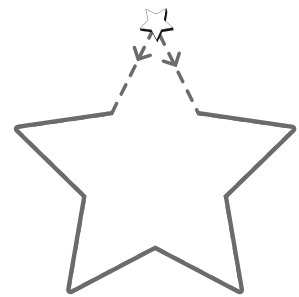
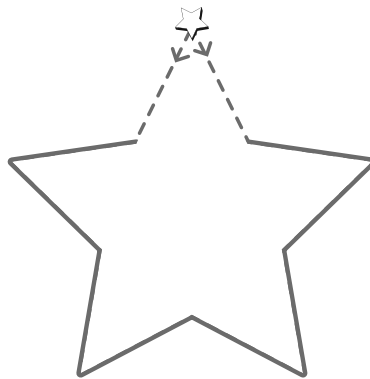
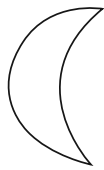

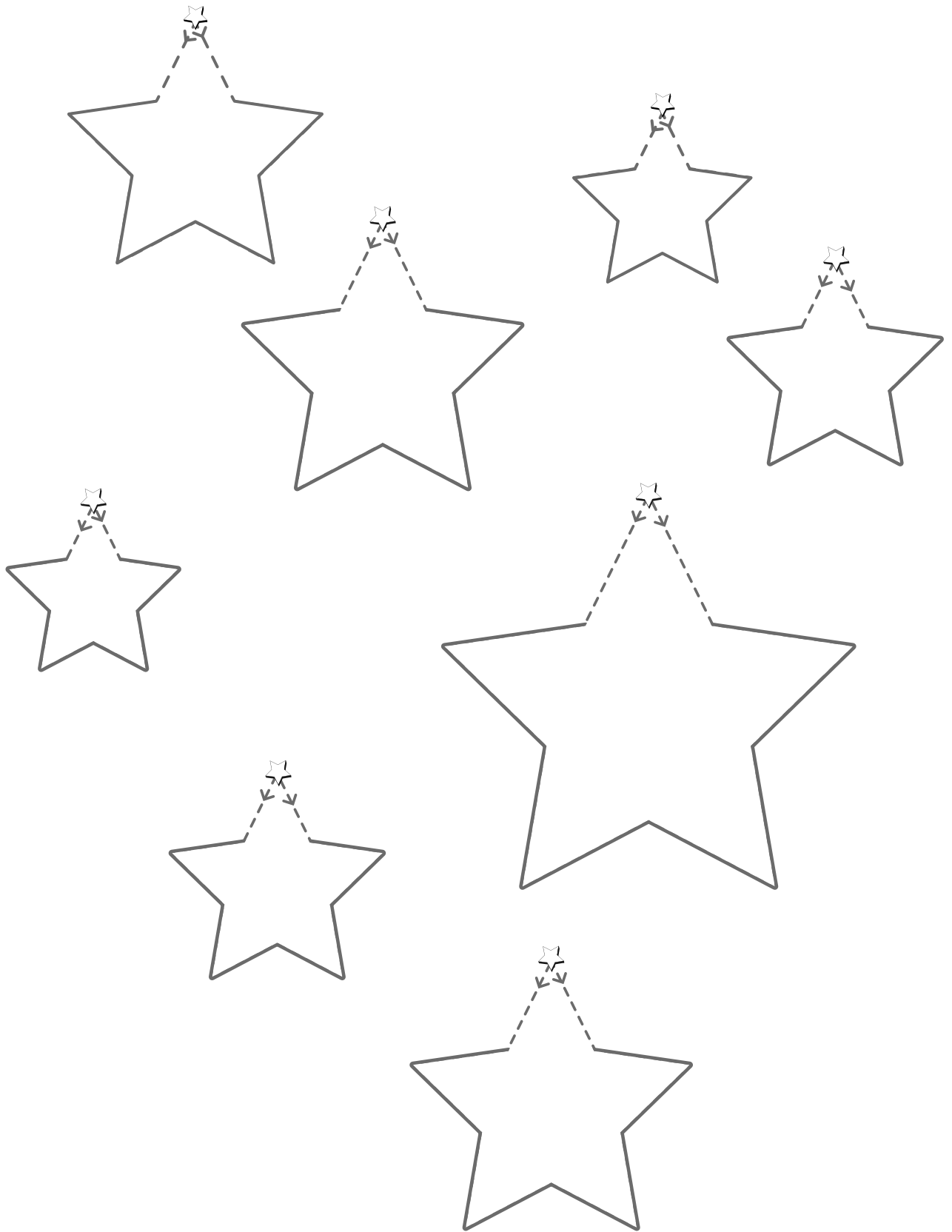

Directions: Ask students to trace the dotted lines, starting at the stars and moving down on the front of the worksheet and moving to the right on the back of the worksheet. Students may color the pictures (optional).

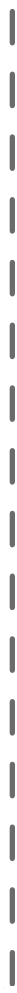

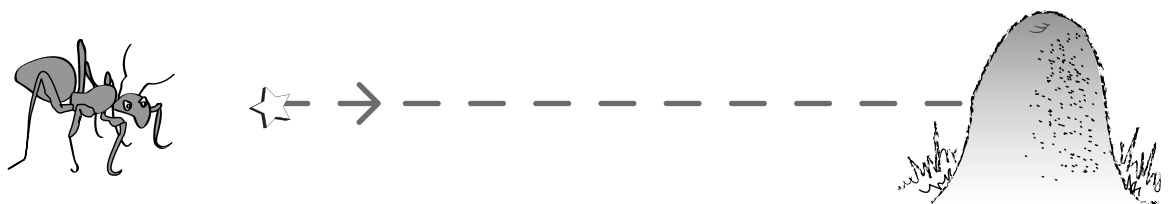
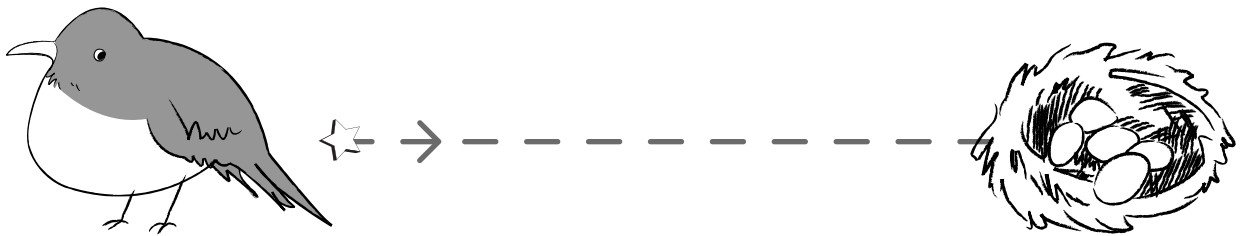
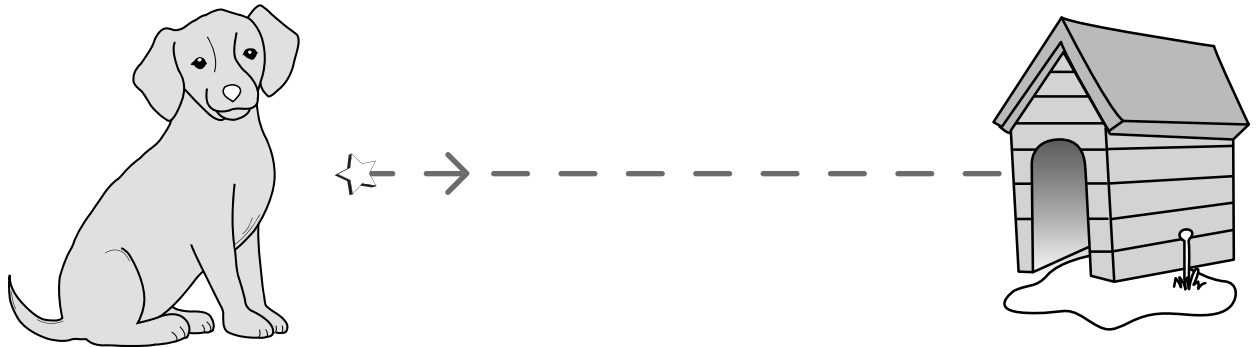
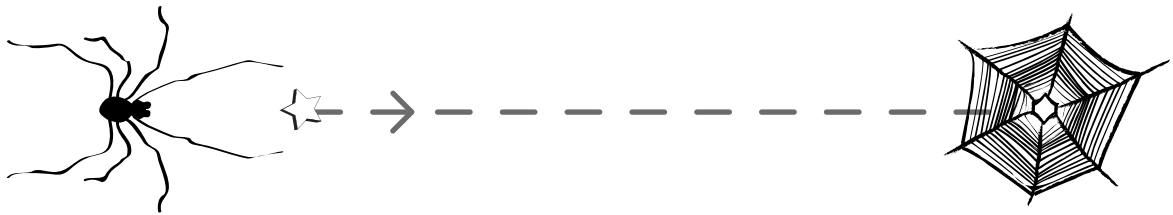
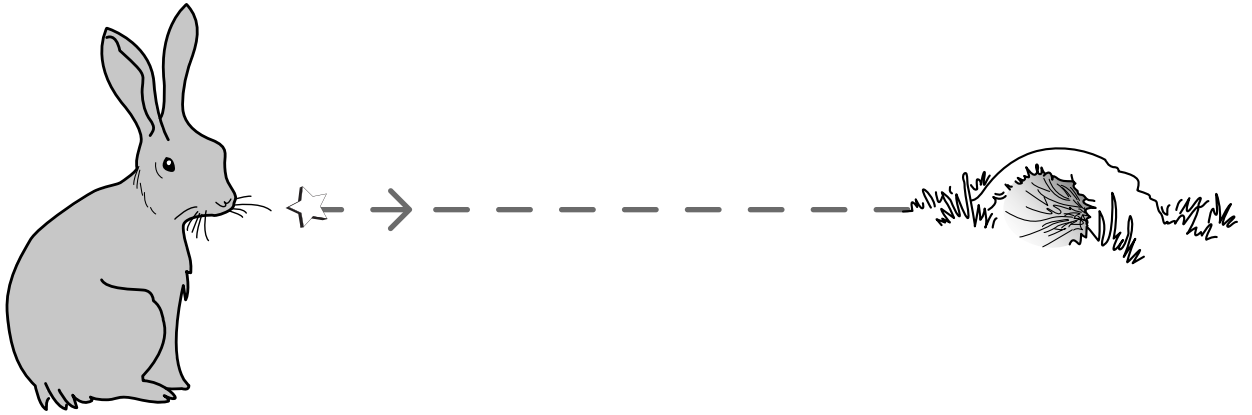

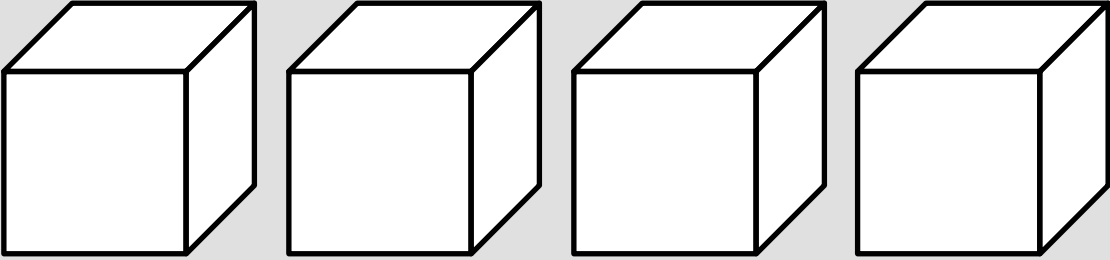

Directions: For each sentence, ask students to circle one cube for each word in the sentence read aloud.

1. 

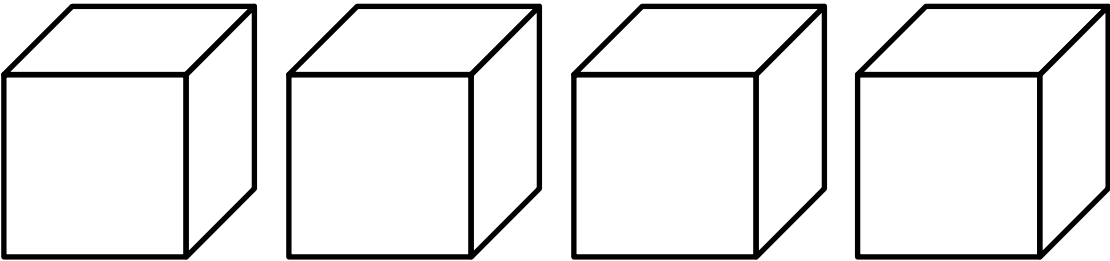
2. 

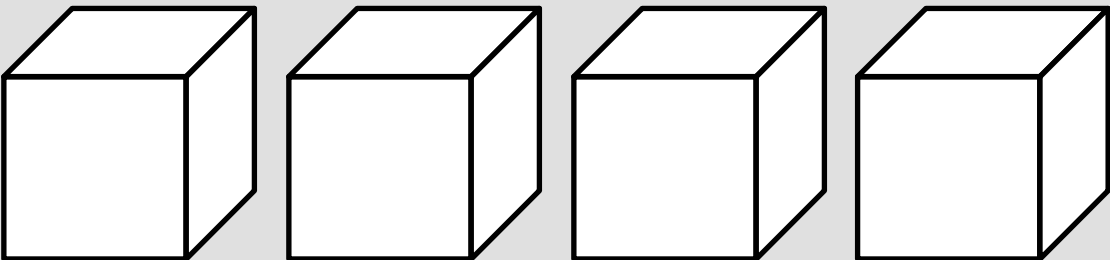
3. 

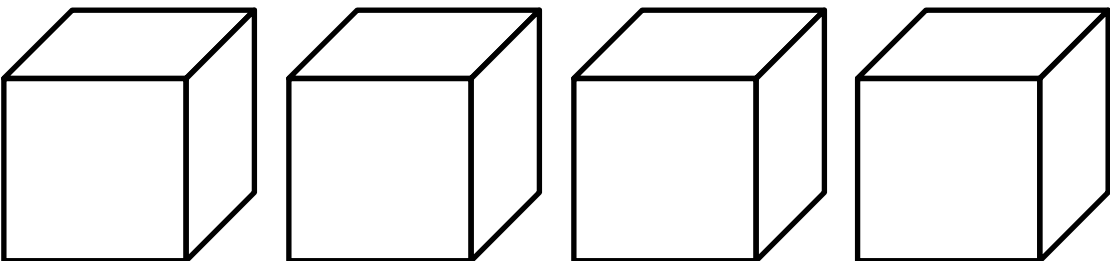
4. 



Directions: Ask students to trace the dotted circles, starting at the stars and moving to the left. Students may color the pictures (optional).

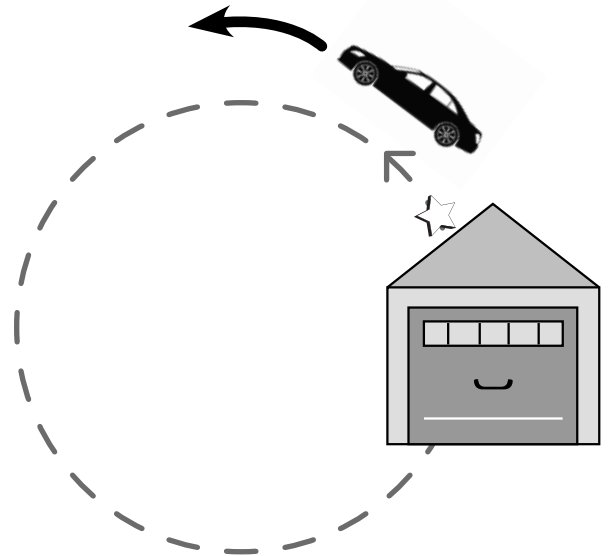
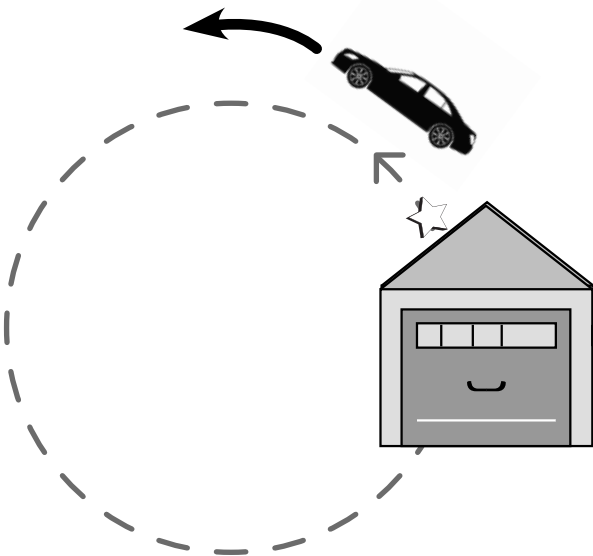
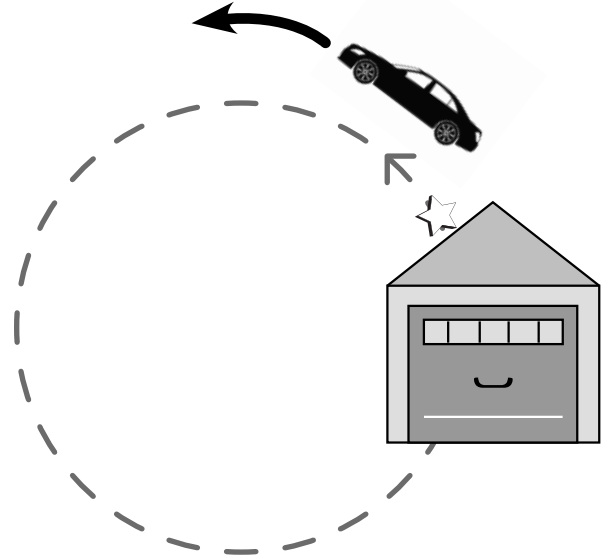
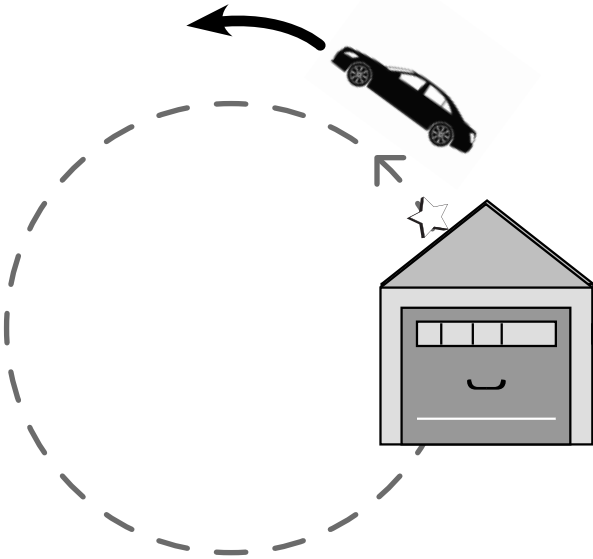
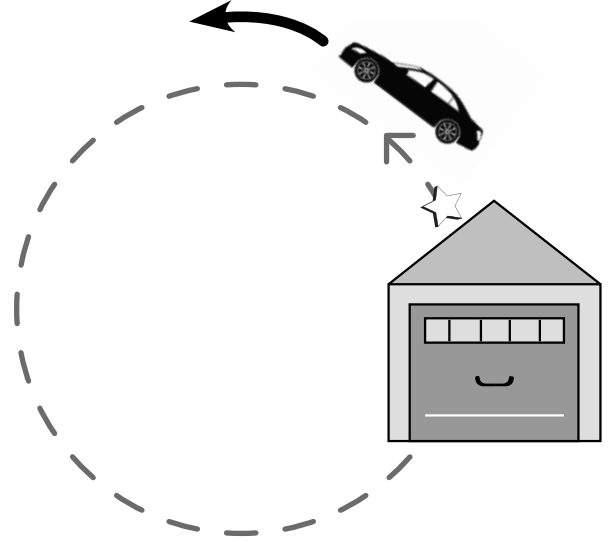
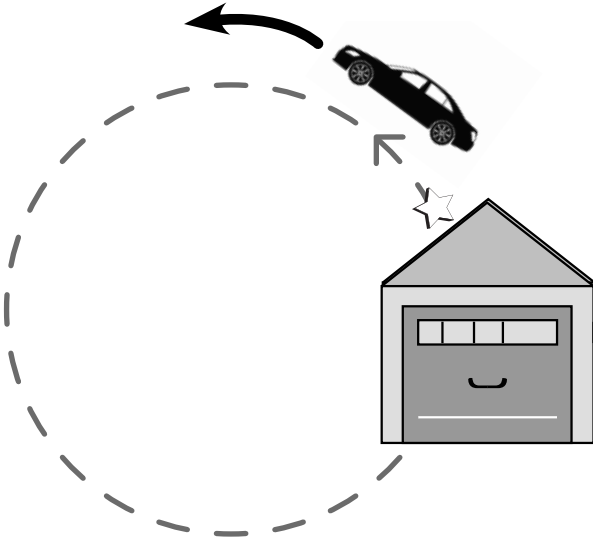

Directions: Ask students to trace the dotted lines, starting at the stars. Students may color the pictures (optional).

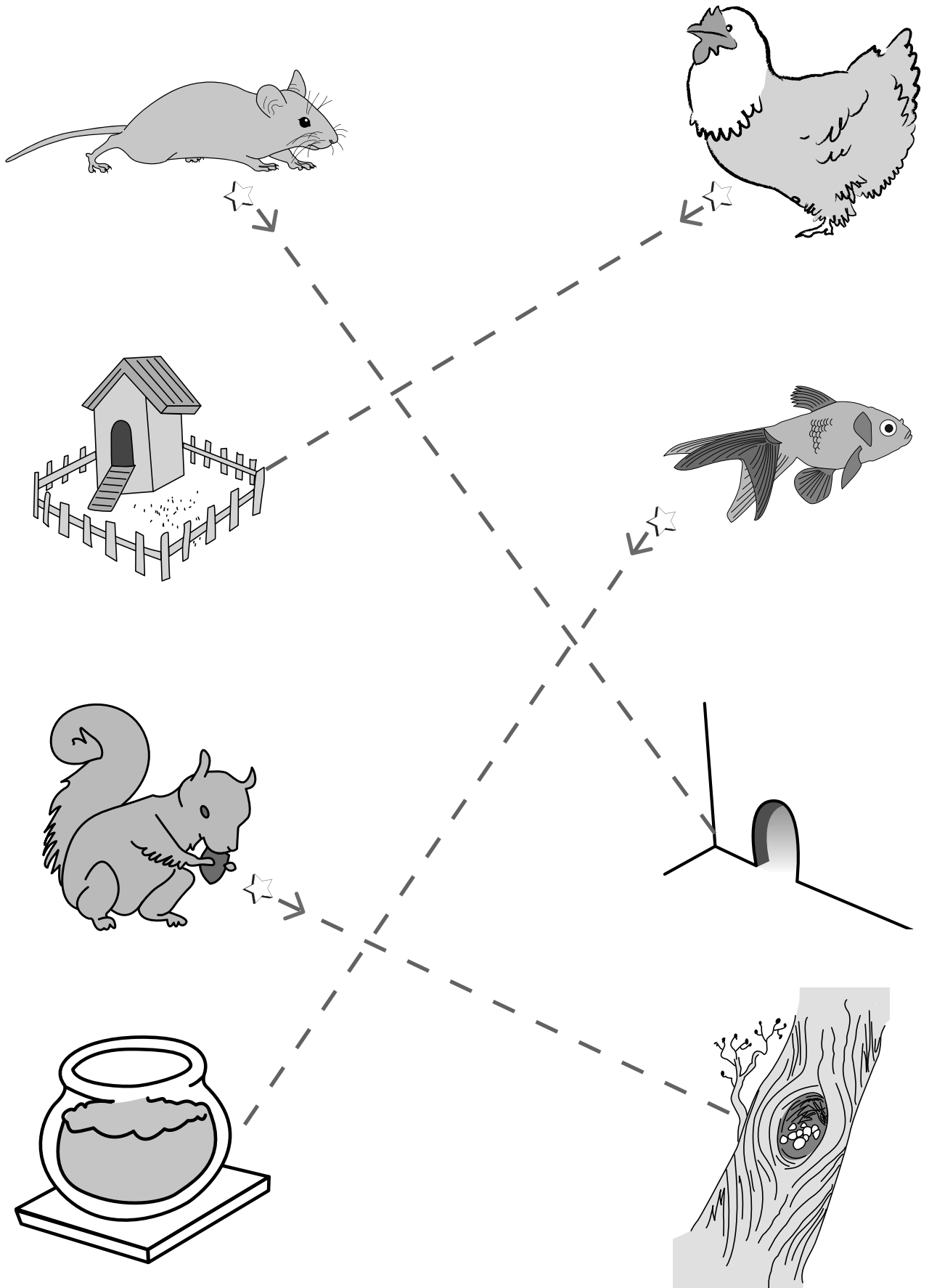

**Dear Family Member,**

In class, we have been using the position words *top*, *bottom*, *left*, *right*, and *middle*. This worksheet is meant to give your child more practice with these words. Giving one direction at a time, ask your child to color the square on the *left* green, the square on the *right* red, the *top* square orange, the *middle* square blue, and the *bottom* square yellow.

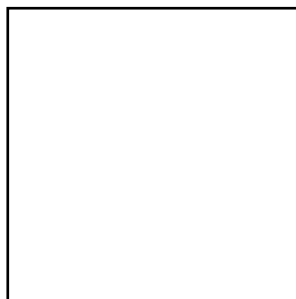
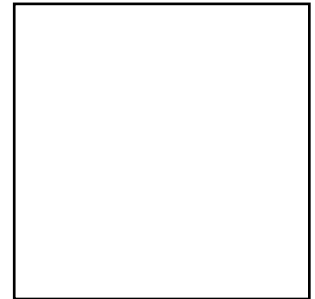
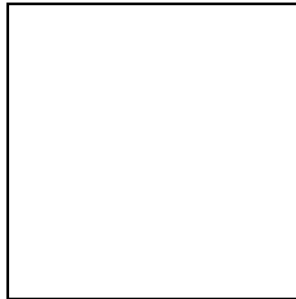
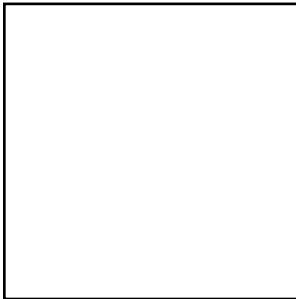
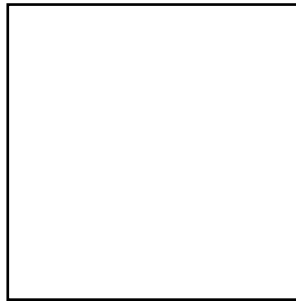



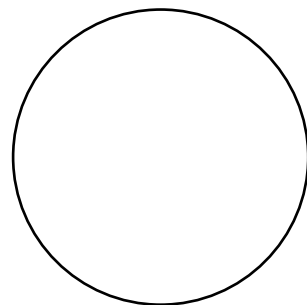
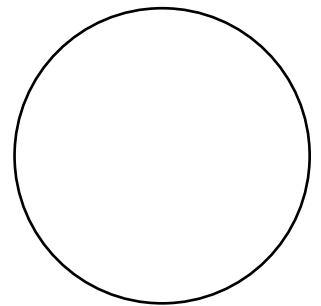
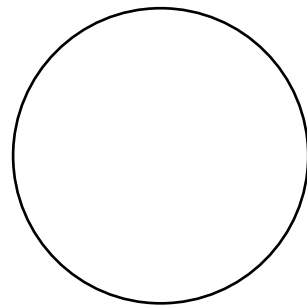
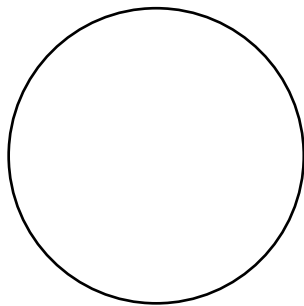
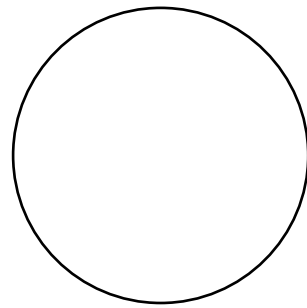

Please direct your child to color the circle on the *left* green, the circle on the *right* red, the *top* circle blue, the *middle* circle yellow, and the *bottom* circle orange. Check your child's work, and review the meanings of the position words if necessary. Use these words in your day-to-day activities, "Put your socks in the middle drawer," "Use your right hand to open the door," etc.



Name \_\_\_\_\_

**10.1**

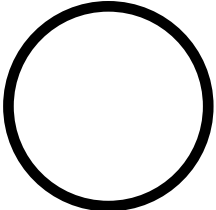
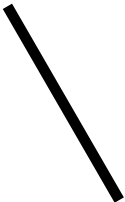
*Part One*

*Directions: Ask students to copy each item.*

Directions: Ask students to color the box on the left green, the box on the right red, the top box yellow, the middle box orange, and the bottom box blue.

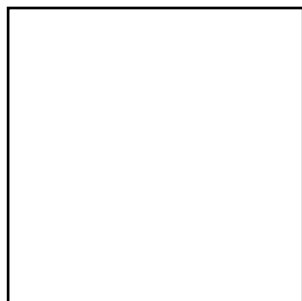
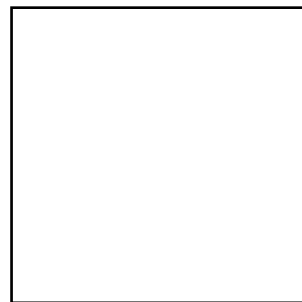
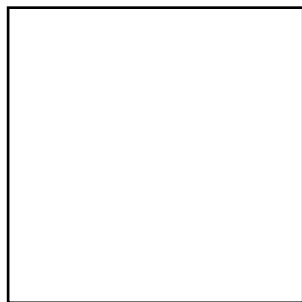
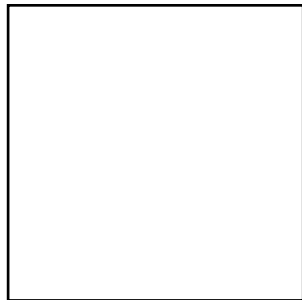
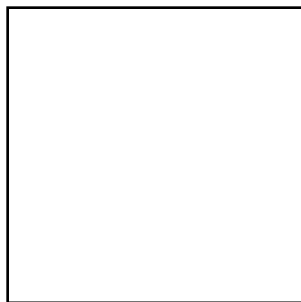

Part One, Writing Strokes Score: \_\_\_\_\_  
Part Two, Position Words Score: \_\_\_\_\_

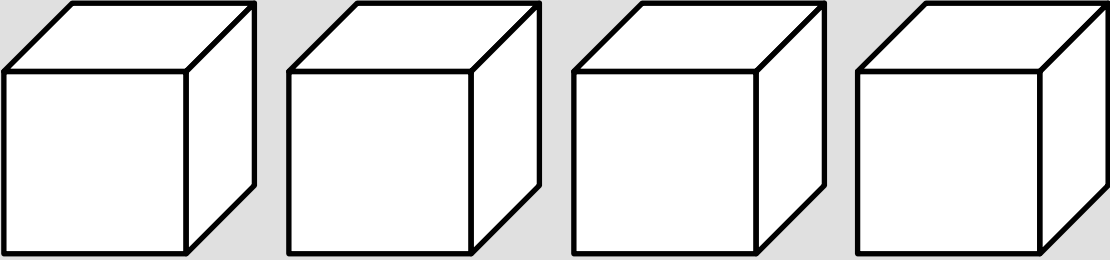

*Directions: For each sentence, ask students to circle one cube for each word in the sentence read aloud.*

**1.** 

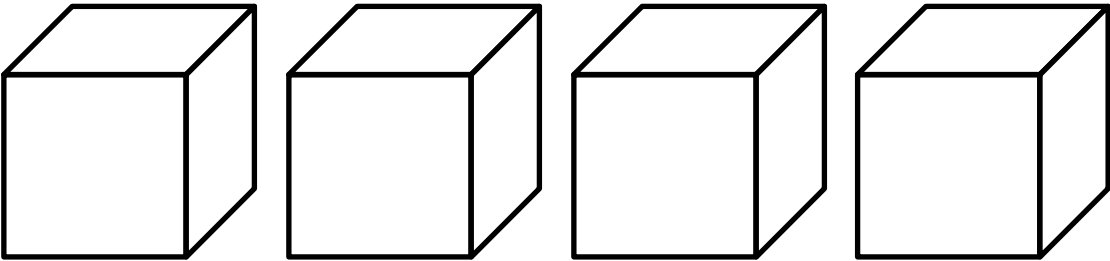
**2.** 

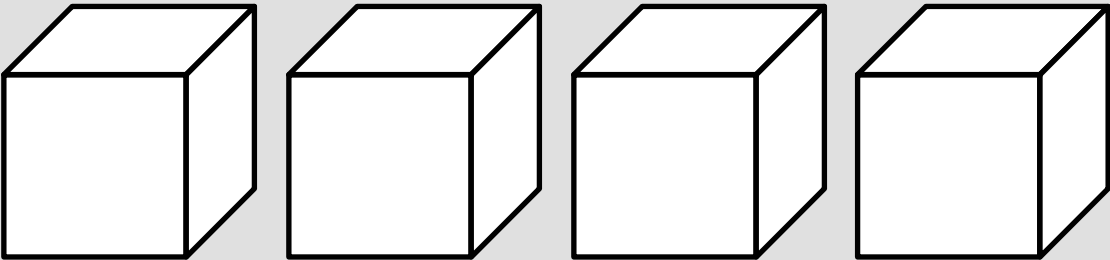
**3.** 

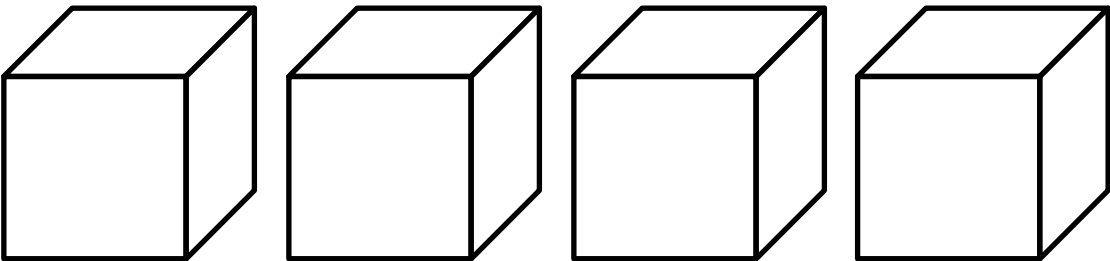
**4.** 

*Part Three, Word Discrimination Score:* \_\_\_\_\_



**Dear Family Member,**

When we read, we track from left to right and top to bottom. This worksheet will help familiarize your child with the directionality of reading. Have your child name and point to the pictures in each row from left to right on the front and back of this worksheet. Your child should identify the pictures in the top row, then the pictures in the second row, then the pictures in the third row, and then the pictures in the bottom row.

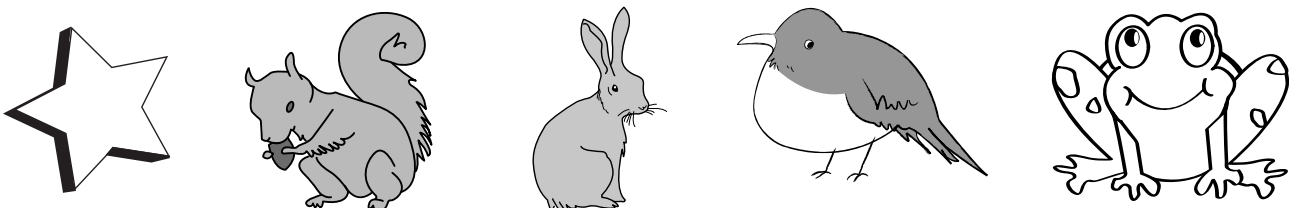
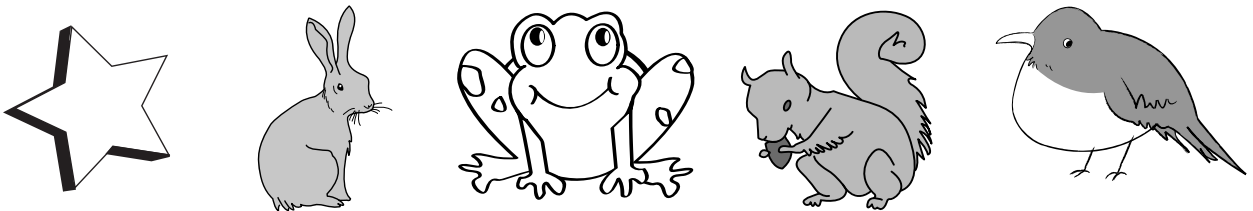
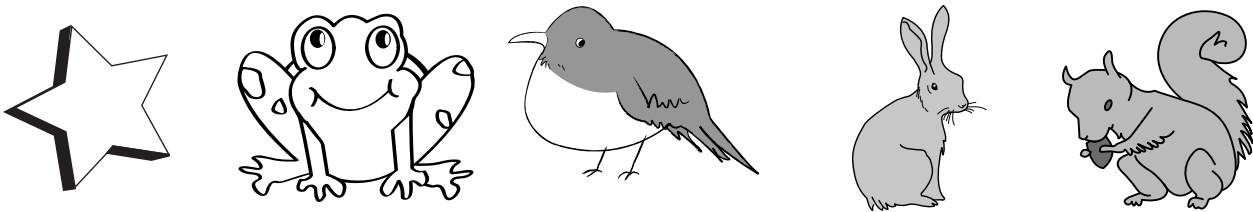
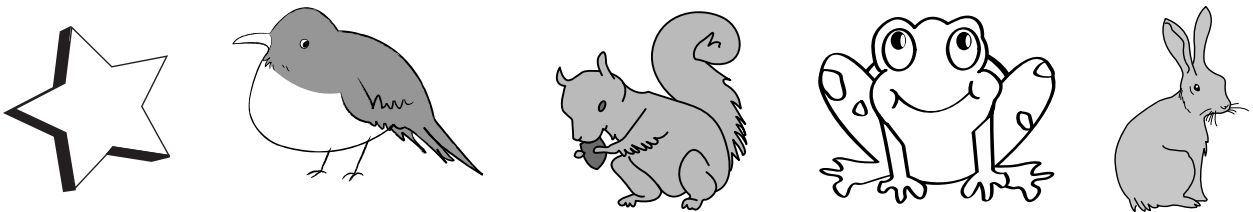

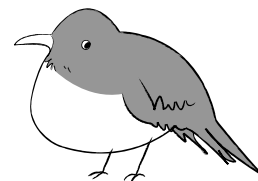
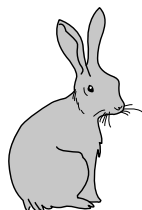
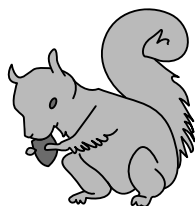
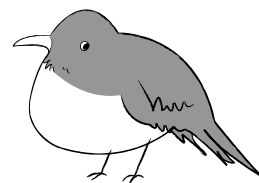
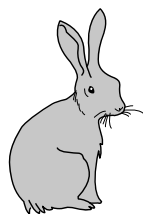
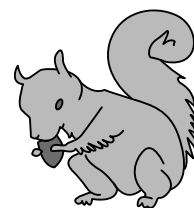
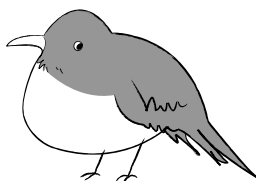
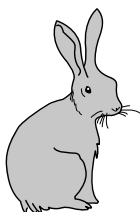
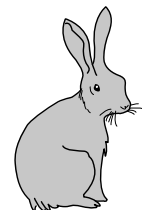
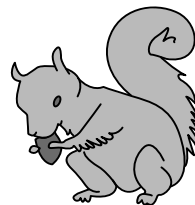
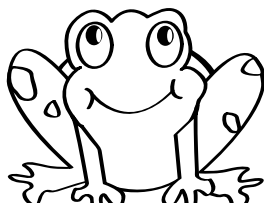
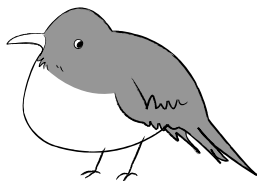

Name \_\_\_\_\_

*Directions: Ask students to color the left hand green and the right hand red. Students may decorate the hands (optional).*

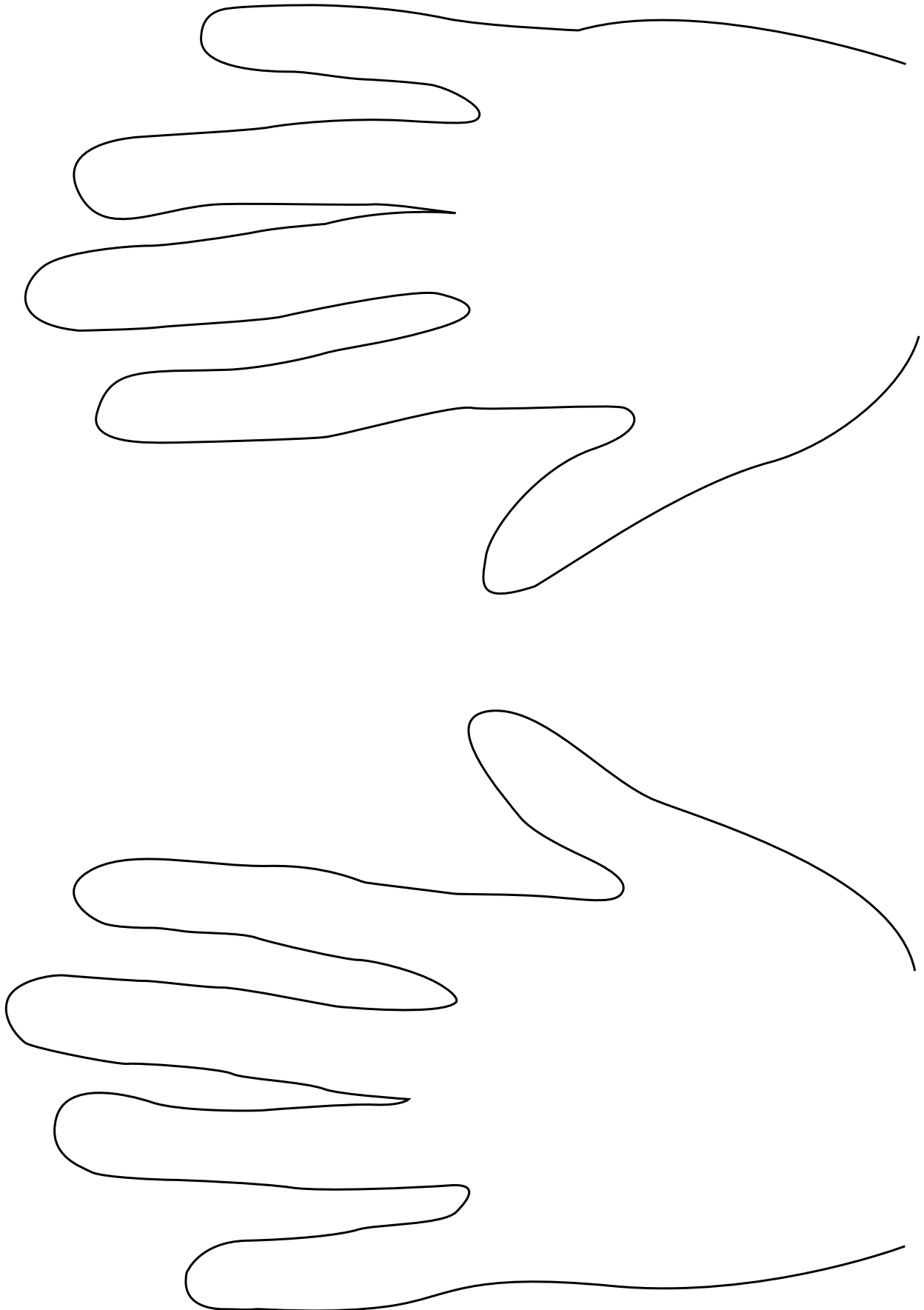



*Directions: Ask students to trace the outline of the figure several times. Students may color in the figure.*

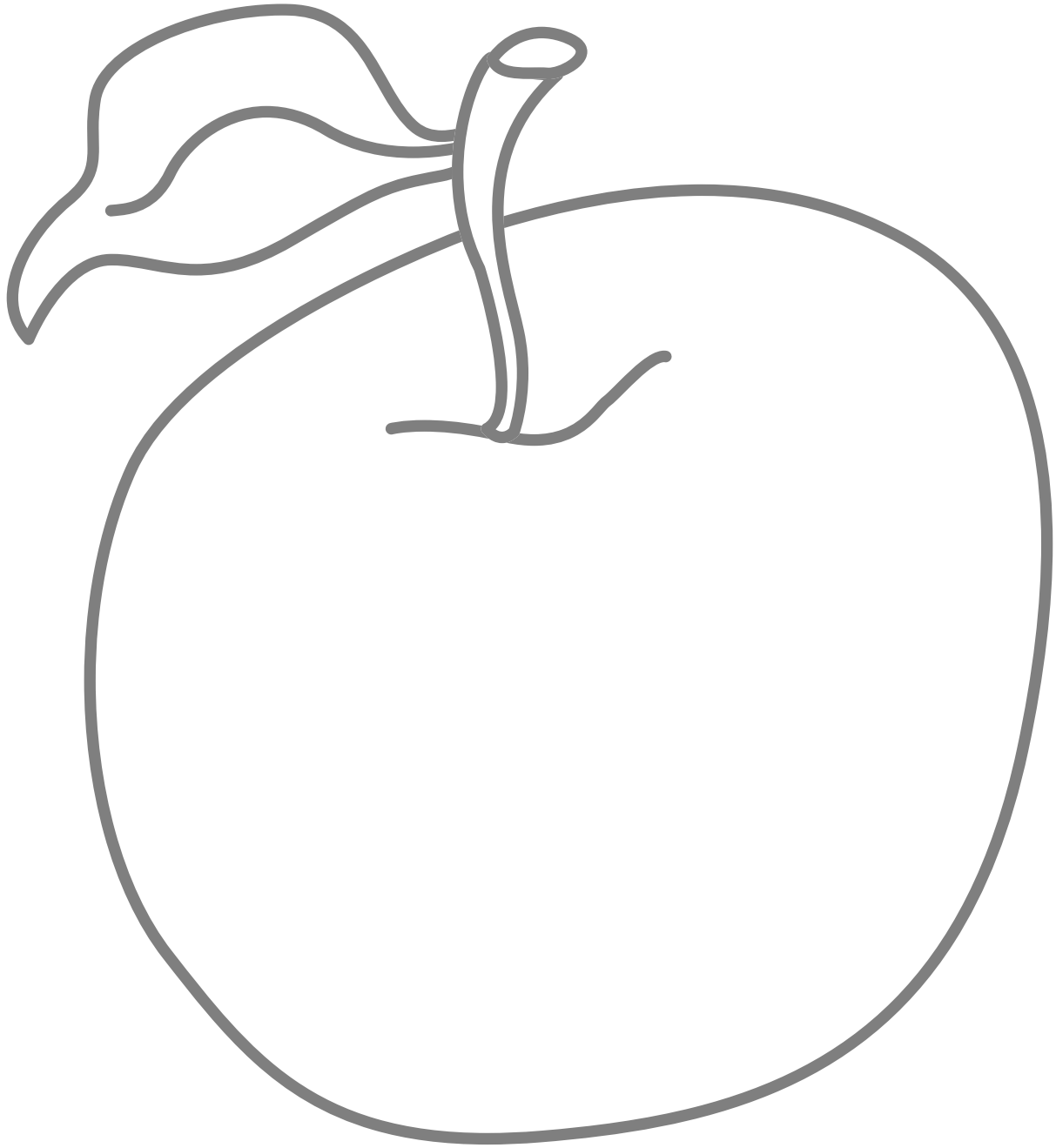





*Directions: Ask students to trace the outline of the figure several times. Students may color in the figure.*

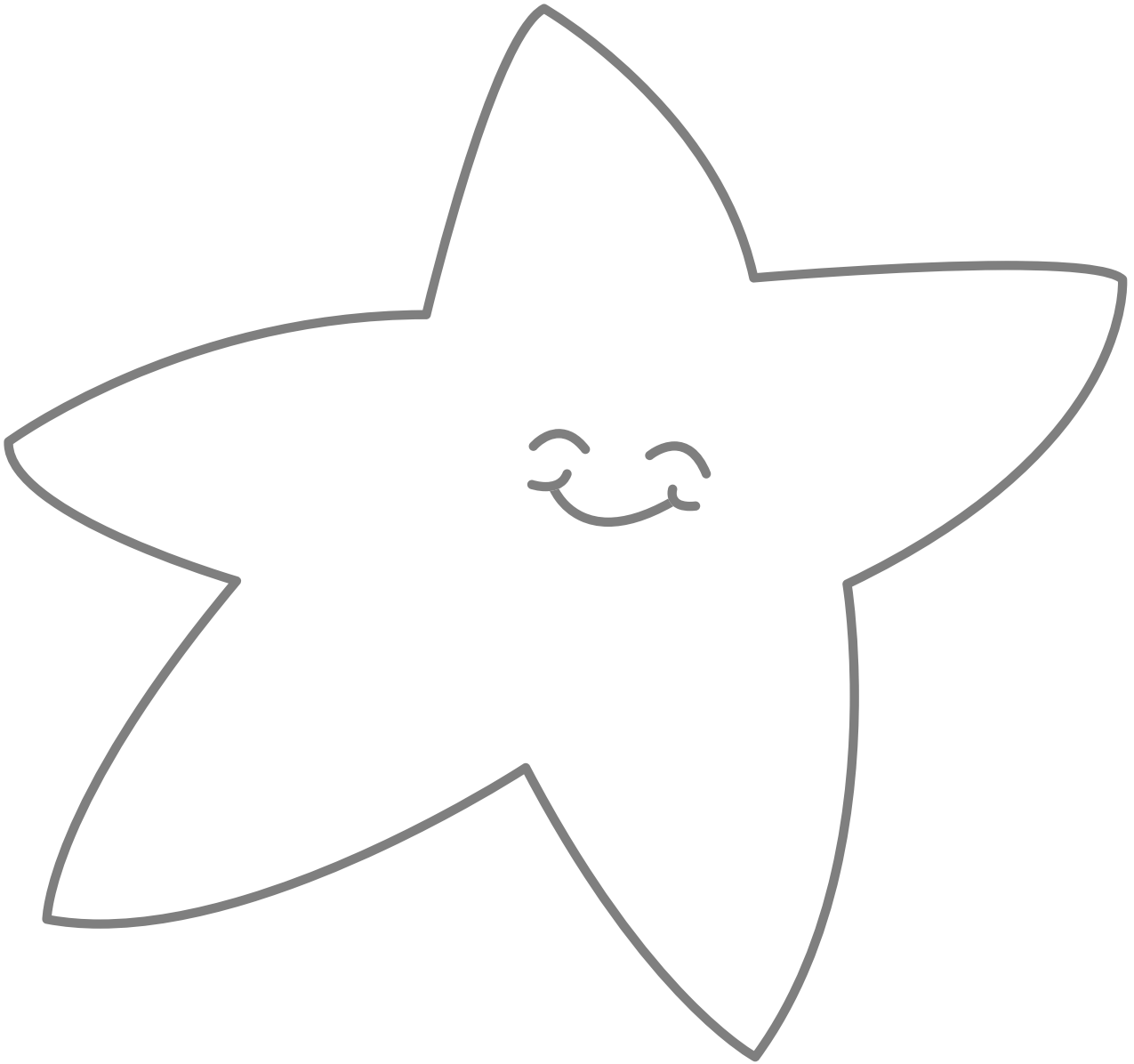



Name \_\_\_\_\_

*Directions: Ask students to trace the outline of the figure several times. Students may color in the figure.*

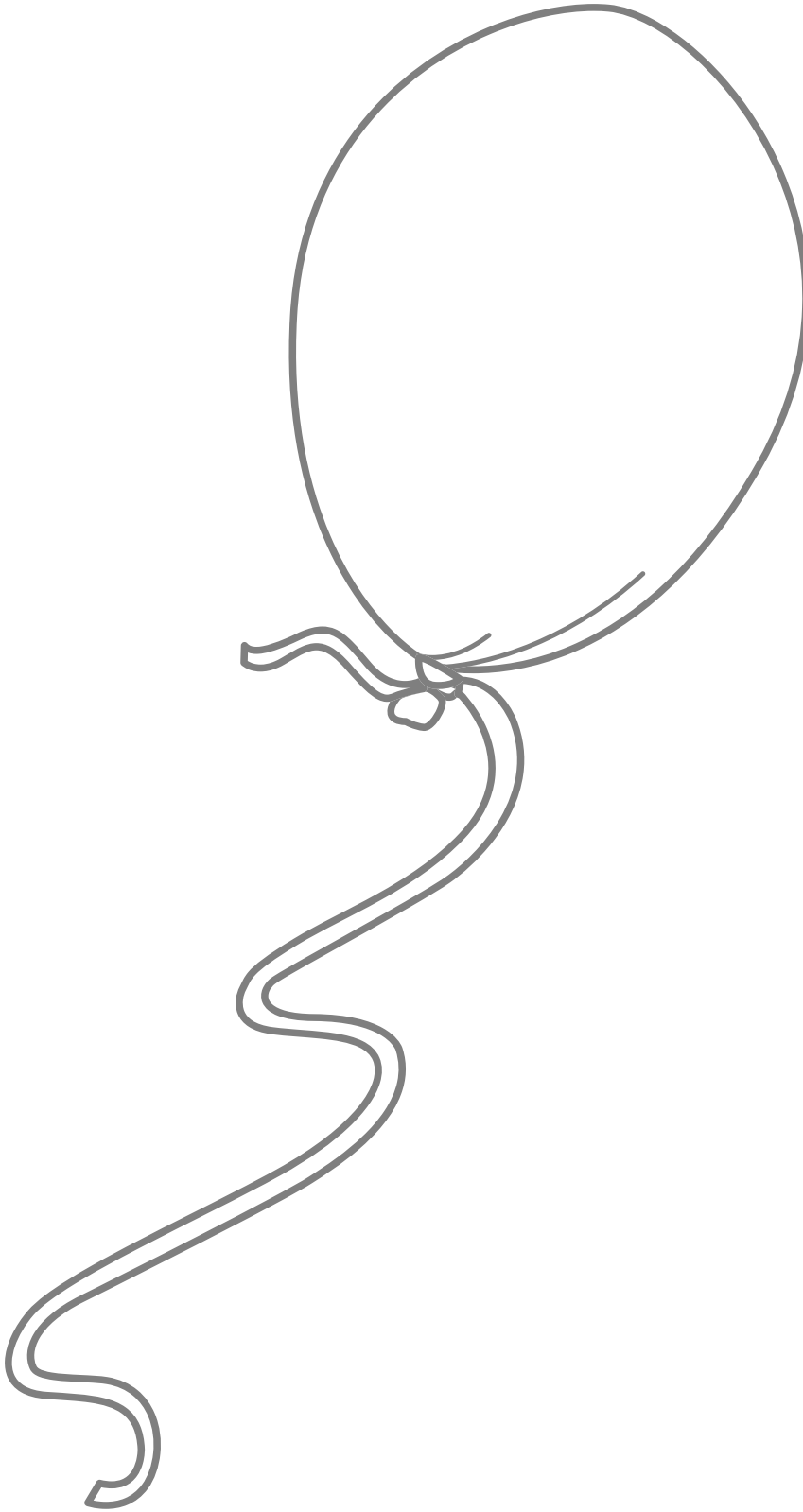





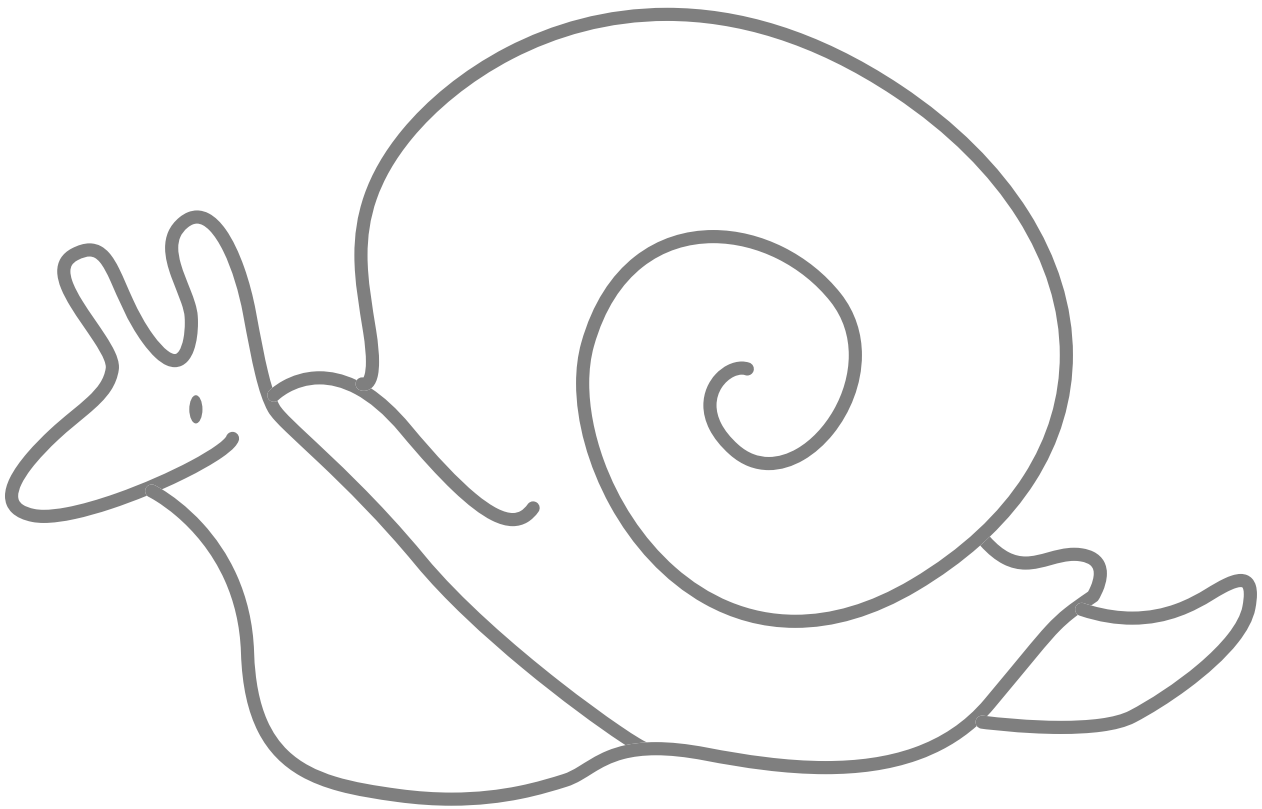



*Directions: Ask students to trace the outline of the figure several times. Students may color in the figure.*



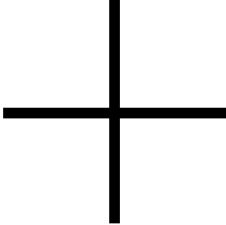
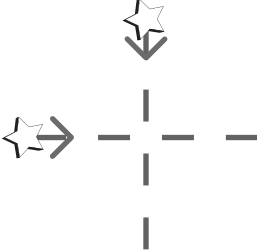
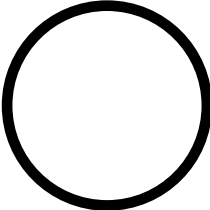
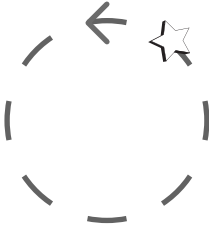
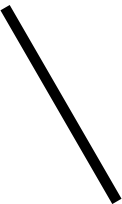
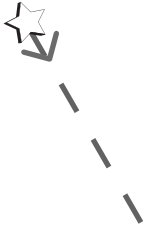

Name \_\_\_\_\_

Directions: Ask students to first trace and then draw the shape.

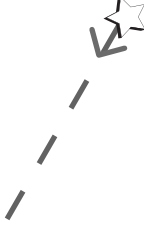

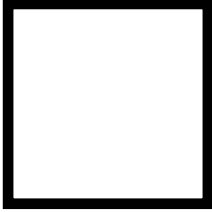
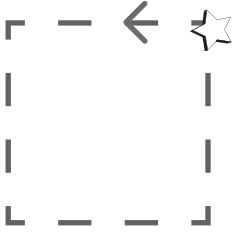
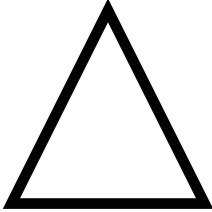
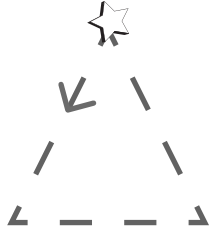
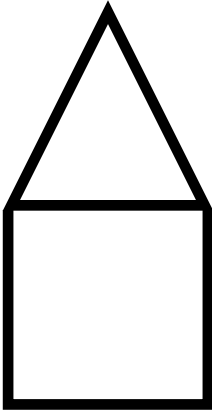
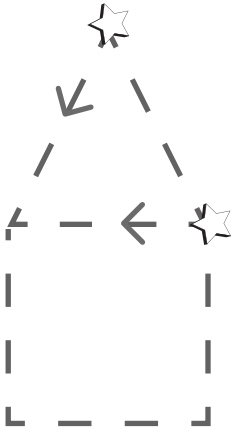
# CORE KNOWLEDGE LANGUAGE ARTS

## SERIES EDITOR-IN-CHIEF

E. D. Hirsch, Jr.

## PRESIDENT

Linda Bevilacqua

### EDITORIAL STAFF

Carolyn Gosse, Senior Editor - Preschool  
Khara Turnbull, Materials Development Manager  
Michelle L. Warner, Senior Editor - Listening & Learning

Mick Anderson  
Robin Blackshire  
Maggie Buchanan  
Paula Coyner  
Sue Fulton  
Sara Hunt  
Erin Kist  
Robin Luecke  
Rosie McCormick  
Cynthia Peng  
Liz Pettit  
Ellen Sadler  
Deborah Samley  
Diane Auger Smith  
Sarah Zelinke

### DESIGN AND GRAPHICS STAFF

Scott Ritchie, Creative Director

Kim Berrall  
Michael Donegan  
Liza Greene  
Matt Leech  
Bridget Moriarty  
Lauren Pack

### CONSULTING PROJECT MANAGEMENT SERVICES

ScribeConcepts.com

### ADDITIONAL CONSULTING SERVICES

Ang Blanchette  
Dorrit Green  
Carolyn Pinkerton

## ACKNOWLEDGMENTS

These materials are the result of the work, advice, and encouragement of numerous individuals over many years. Some of those singled out here already know the depth of our gratitude; others may be surprised to find themselves thanked publicly for help they gave quietly and generously for the sake of the enterprise alone. To helpers named and unnamed we are deeply grateful.

### CONTRIBUTORS TO EARLIER VERSIONS OF THESE MATERIALS

Susan B. Albaugh, Kazuko Ashizawa, Nancy Braier, Kathryn M. Cummings, Michelle De Groot, Diana Espinal, Mary E. Forbes, Michael L. Ford, Ted Hirsch, Danielle Knecht, James K. Lee, Diane Henry Leipzig, Martha G. Mack, Liana Mahoney, Isabel McLean, Steve Morrison, Juliane K. Munson, Elizabeth B. Rasmussen, Laura Tortorelli, Rachael L. Shaw, Sivan B. Sherman, Miriam E. Vidaver, Catherine S. Whittington, Jeannette A. Williams

We would like to extend special recognition to Program Directors Matthew Davis and Souzanne Wright who were instrumental to the early development of this program.

### SCHOOLS

We are truly grateful to the teachers, students, and administrators of the following schools for their willingness to field test these materials and for their invaluable advice: Capitol View Elementary, Challenge Foundation Academy (IN), Community Academy Public Charter School, Lake Lure Classical Academy, Lepanto Elementary School, New Holland Core Knowledge Academy, Paramount School of Excellence, Pioneer Challenge Foundation Academy, New York City PS 26R (The Carteret School), PS 30X (Wilton School), PS 50X (Clara Barton School), PS 96Q, PS 102X (Joseph O. Loretan), PS 104Q (The Bays Water), PS 214K (Michael Friedsam), PS 223Q (Lyndon B. Johnson School), PS 308K (Clara Cardwell), PS 333Q (Goldie Maple Academy), Sequoyah Elementary School, South Shore Charter Public School, Spartanburg Charter School, Steed Elementary School, Thomas Jefferson Classical Academy, Three Oaks Elementary, West Manor Elementary.

And a special thanks to the CKLA Pilot Coordinators Anita Henderson, Yasmin Lugo-Hernandez, and Susan Smith, whose suggestions and day-to-day support to teachers using these materials in their classrooms was critical.



## CREDITS

*Every effort has been taken to trace and acknowledge copyrights. The editors tender their apologies for any accidental infringement where copyright has proved untraceable. They would be pleased to insert the appropriate acknowledgment in any subsequent edition of this publication. Trademarks and trade names are shown in this publication for illustrative purposes only and are the property of their respective owners. The references to trademarks and trade names given herein do not affect their validity.*

*All photographs are used under license from Shutterstock, Inc. unless otherwise noted.*

### ILLUSTRATORS AND IMAGE SOURCES

Cover: Shutterstock; Title Page: Shutterstock; Take Home Icon: Core Knowledge Staff; 2.1: Core Knowledge Staff; 3.1: Core Knowledge Staff; 3.2: Core Knowledge Staff; 4.2: Core Knowledge Staff; 4.3: Core Knowledge Staff; 5.1: Core Knowledge Staff; 5.2: Core Knowledge Staff; 6.3: Core Knowledge Staff; 7.1: Core Knowledge Staff; 7.2: Core Knowledge Staff; 7.3: Core Knowledge Staff; 8.1: Core Knowledge Staff; 8.2: Core Knowledge Staff; 9.1: Core Knowledge Staff; 9.2: Core Knowledge Staff; 10.2: Core Knowledge Staff; 10.3: Core Knowledge Staff; PP1: Core Knowledge Staff; PP2: Core Knowledge Staff; PP3: Core Knowledge Staff; PP4: Core Knowledge Staff; PP5: Core Knowledge Staff

Regarding the Shutterstock items listed above, please note: No person or entity shall falsely represent, expressly or by way of reasonable implication, that the content herein was created by that person or entity, or any person other than the copyright holder(s) of that content.





Core Knowledge®

# Unit 1

## Skills Workbook

Skills Strand  
**KINDERGARTEN**

The Core Knowledge Foundation  
[www.coreknowledge.org](http://www.coreknowledge.org)